

Your Visual Safety Guide



Contents

1. Transportation	7	11. Lashing Equipment Housekeeping	85
2. Suspended Loads and Lifting.....	14	12. Three Container Separation	92
3. Working at Height.....	23	13. Lashing Twistlock Troubleshooting.....	100
4. Personal Fall Protection Equipment (PFPE).....	33	14. Working at Height during Lashing and Unlashing	113
5. Stored Energy	41	15. Lashing and Unlashing Working in Pairs.....	121
6. Control of Contractors	51	16. Out of Gauge (OOG) using STS Cranes.....	129
7. Conducting a Vessel Safety Inspection	60	17. Packing and Stripping Containers (x-staffing).....	138
8. Vessel Inspection Engagement Agreements	69	18. Rental Equipment Management	150
9. Lashing Personal Protective Equipment.....	73	19. Tyre Management.....	162
10. Lashing Workplace Risk Assessment	77	20. Working with High Voltage.....	177

Our way of doing business

Time Honoured Values



Constant Care



Humbleness



Uprightness



Our Employees



Our Name





Operations at
APM Terminals MedPort Tangier
Were officially launched in June 2019. It is
one of the most technologically advanced,
safest and efficient terminals in the world.

Our Culture of Safety

Safety means everything to us and to our customers



We protect:



Human lives



The environment



And assets

- Safety is at the heart of what we do. We care for the health and safety of our people and our planet and pride ourselves on being an industry leader in safety performance.
- In addition to protecting our workforce, effectively managing safety risks supports our reputation, improves financial returns, strengthens stakeholder confidence, and increases our competitive advantage.
- These standards assist all managers in delivering on our expectations to protect: our people, our property and equipment, our customers and their cargo, our business partners, and the community. They form part of an overall safety management framework.



HSSE Visual Control Points

1. Transportation



People



Everyone (employees, contractors, visitors, external truck drivers) must complete an induction if it is their first time on site so they are aware of the transportation risks and the controls that keep them safe.

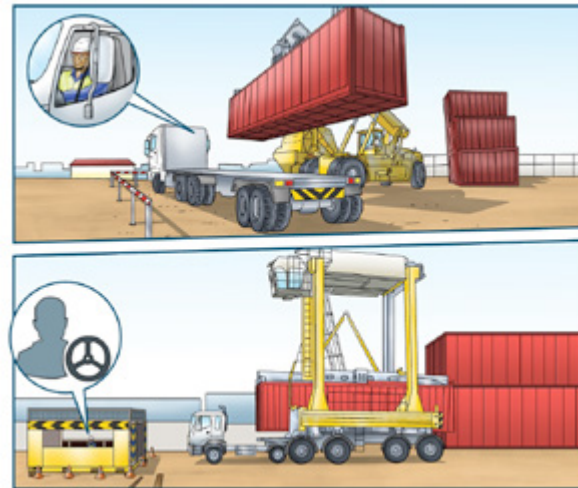
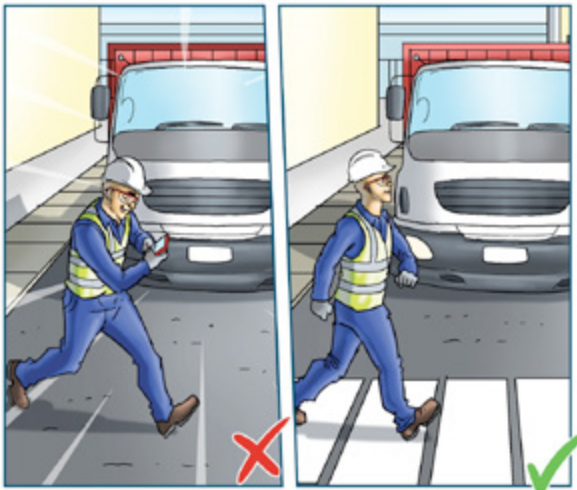

People



Pedestrians must be aware and comply with:

1. Use walkways and road crossings;
2. Use radios and mobile phones **ONLY** in designated areas;
3. **DO NOT** use personal entertainment devices in the work environment;
4. Wear high-visibility clothing/PPE; and
5. Only approach equipment if authorized to do so and after making contact with the operator.



Truck Drivers must be aware and comply with:

1. Stay inside their vehicles **during** forklift, reach stacker or other mobile equipment maneuvers;
2. **Stand out** in designated safe areas during Shuttle Carrier or Crane load/discharge operations;
3. Only secure or unsecure loads in designated areas.
4. Do not drive without securing the load.
5. For external trucks, **DO NOT** bring other passengers or pets on site;

People

Mobile equipment includes light vehicles, buses, trucks, stackers, forklifts, Shuttles, etc.



Mobile equipment operators :



are competent and have current licences and permits



know and follow traffic management plans



check loads are secure before they are moved



report damage or problems



DO NOT deactivate limit switches/safety devices



DO NOT leave equipment idling and unattended



DO NOT get distracted

Process

An **up-to-date traffic management plan is a must.** And terminal users need to be aware about the traffic rules. Traffic management plans are reviewed once a year and/or after an incident / change in operations. TM2 have a **terminal layout plan** that minimizes by design risks to pedestrians, mobile equipment operators and external truck drivers.

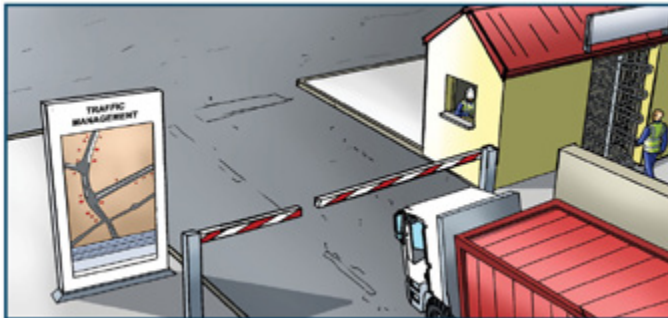

The plan should:

1. Following Risk Assessment, Terminal TMP is split over 3 zones as:



Zone A – unrestricted and free access to any person or vehicle



Zone B – only those who have been trained, inducted (made aware of the risks), authorised and are wearing PPE may walk in these areas



Zone C – “No Walk” zone. People can only enter if all mobile equipment is stopped

1. Workstations, pinning stations, equipment, bins, racks, etc. are located in areas clear of the regular paths of mobile equipment;
1. Safe areas for external trucks to pin and unpin loads outside of operational areas are designated.

Equipment



1. **Maintain** all mobile equipment in a safe condition and keep maintenance records and test certificates.
2. Make mobile equipment **visible** by using reflective tape, lights and beacons.



1. **Safety** devices (such as ROPS/FOPS, reversing alarms, anti-slip stairs, etc.) on equipment are identified by risk assessment and/or required by legislation.

Equipment

Terminal need to maintain roadways, walkways and layouts to minimize risks to pedestrians and maintain safe transport movements.

This includes availability and maintenance of:

- Pedestrian walkways that should be at least 1m wide, bounded on each side with a continuous line and free from obstructions;
- Road traffic control signs including directions and road separation markings for one and two way traffic flow;
- Lighting levels adequate for the range of operations carried out, including night operations (minimum lighting of 10 lux on access routes for people and mobile equipment; and a minimum of 50 lux in operational areas where people and mobile equipment work in close proximity); and
- Speed reduction measures and discipline.



2. Suspended Loads and Lifting

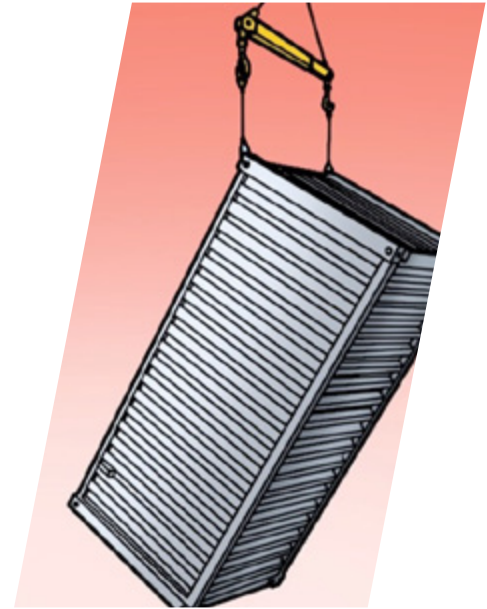

People

All personnel handling loads and directing load handling operations must be :

1. trained and competent;
2. have their competencies regularly assessed; and
3. hold a current and relevant permit, license or certificate of competency, as required by local legislation or as identified by APM Terminals standards.

Sites must ensure that all personnel understand that they should **NEVER** lift loads over people or walk or drive under suspended loads.

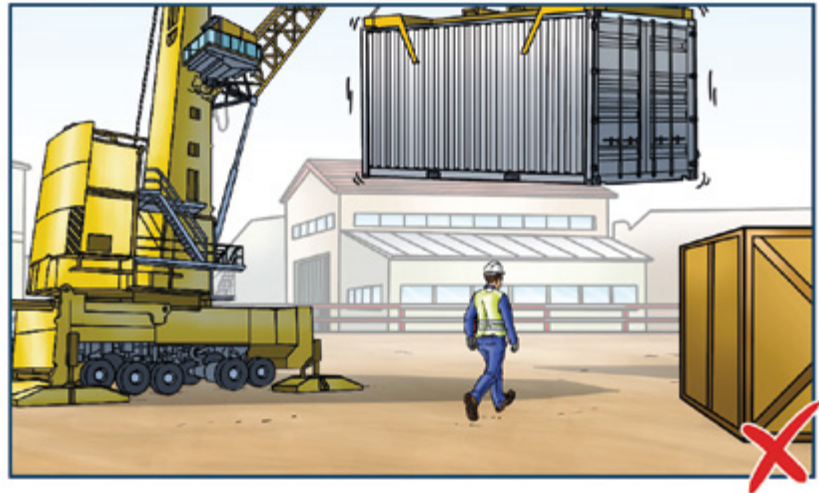

Process:

Sites must perform risk assessments to identify and manage the hazards and risks of load-handling.

Minimum controls must include:



correct
maintenance
handling

selection of essential
load-
equipment.



trained and competent
operators.

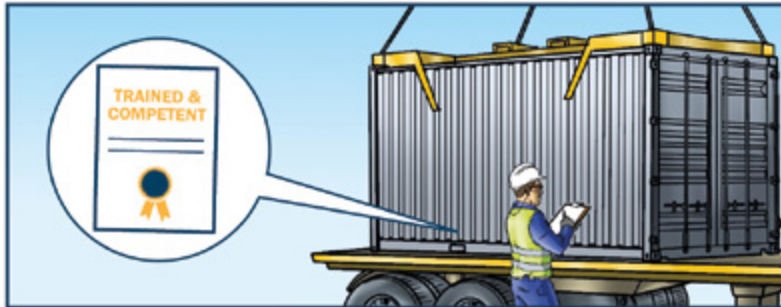

Terminal have specific processes/lifting plans for different types of cargoes handled, such as containers, tank loads, irregular or out of gauge loads.

Terminal also have specific processes for dealing with high-wind events.

No Vertical Tandem Lift operations is allowed, regardless of equipment used, are carried out within terminal premises.

Process:

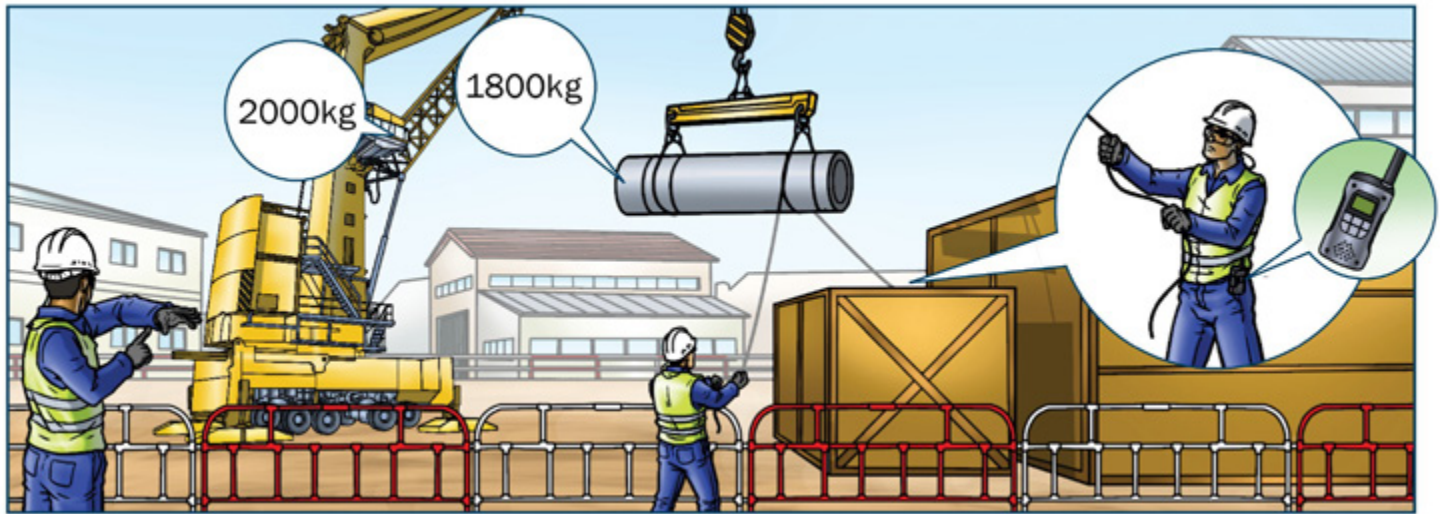

Load weight shall never exceed the lifting equipment or lifting accessories capacity, the Working Load Limit (WLL).

Process:

A competent person is appointed as the **'person in charge'** of the load handling operations and is:

1. the only person signalling and directing operations;
2. clearly identifiable;
3. positioned so that a clear line of sight is maintained at all times. Where this is not possible, then an alternative safe method of work shall be agreed; and
4. responsible for ensuring all personnel are in safe positions and clear of lifting or lowering loads.



If anyone has any doubt about the safety of a load – **DO NOT LIFT.**

Process:

During loading operations, the following controls must be in place:



Loads DO NOT exceed the Working Load Limit (WLL).



Loads ARE NOT carried or **lifted over personnel or vehicles.**



Personnel in contact with moving or suspended loads is minimized. E.g. if needed **use tag lines to guide** loads from safe distance.



There is a clear line of sight with other personnel assisting with the operation. Use radios and a safe system of work where a clear line of sight is not possible.

Equipment

Load-handling gear/equipment requirements



Load-handling gear/equipment is **inspected** and **maintained** in a safe condition with maintenance records and test certificates.



A lifting gear register is maintained in compliance with local statutory and APM terminals requirements by a nominated, authorized person.



Mobile cranes are only operated on uniform, **level and firm ground**, at sufficient loadbearing capacity, to withstand the maximum loading of the crane.

Equipment

Load-handling gear/equipment requirements

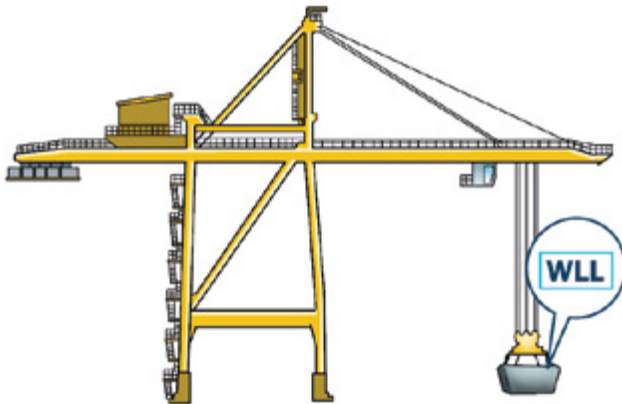

Safety devices such as function labels, WLL tags, limit switches, emergency stop buttons, warning bells or flashing lights and additional devices, determined by risk assessments, law or standards, are fitted to lifting gear/equipment.



All load-handling gear/equipment is inspected immediately **before and after use.**



There is a system in place for **securing, isolating and destroying unsafe lifting equipment** that cannot be repaired.

Equipment

Load-handling gear/equipment requirements

Manual spreaders are prohibited on APM Terminals-controlled sites.

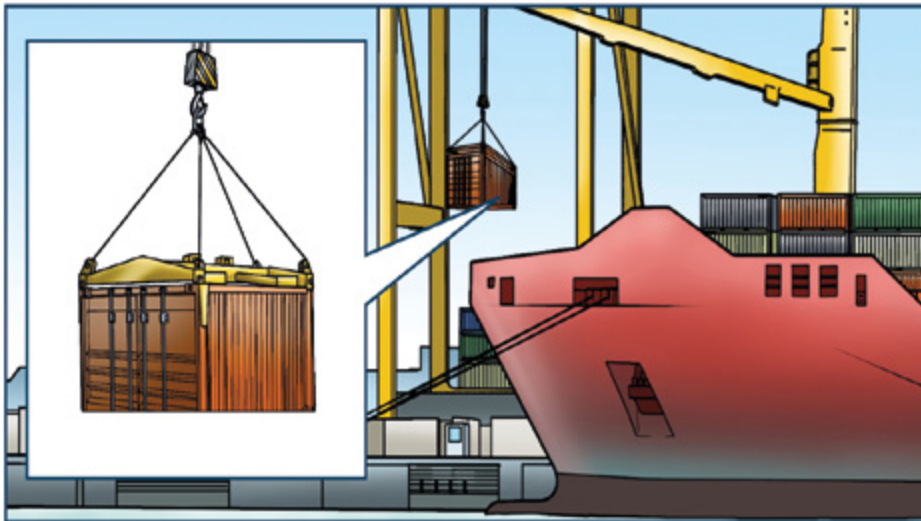

Lifting equipment attachments are stored in **ventilated areas** that are **protected from inclement weather** and **out of direct sunlight**.

All Terminal personnel must **report damage** or mechanical problems with lifting gear/equipment.

Only compliant spreaders **owned by APM Terminals** shall be **used** in operations.

3. Working at Height

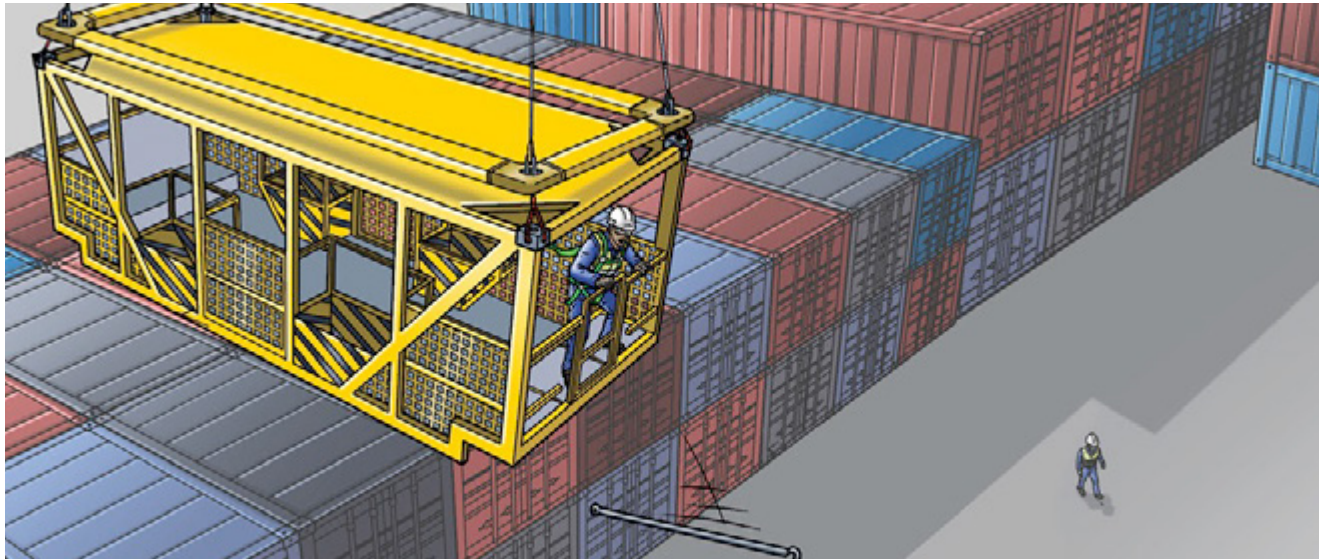

People

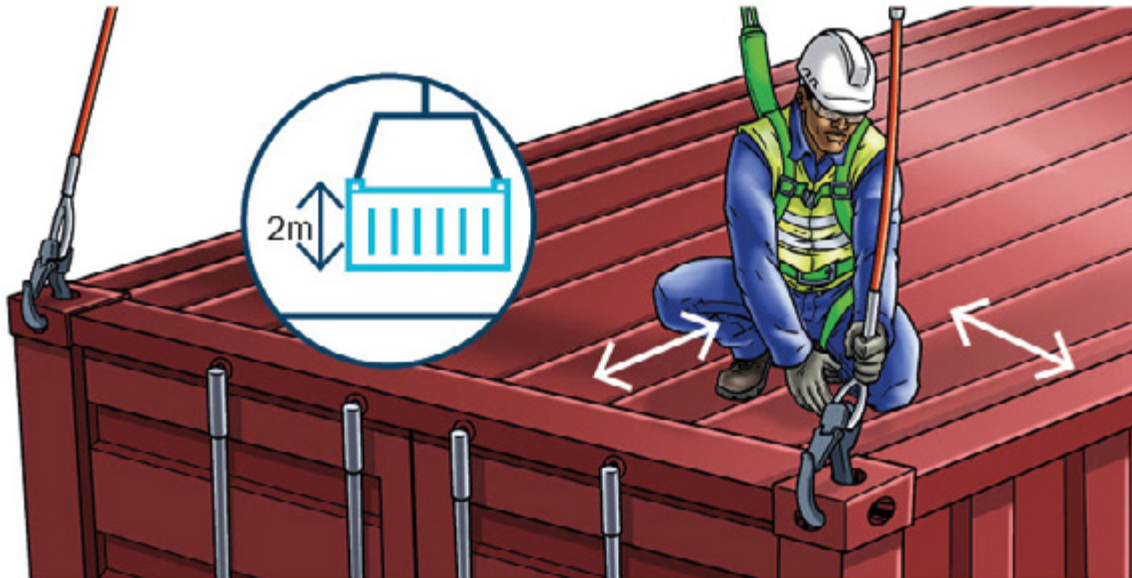

This standard APPLIES whenever there's a risk of falling 2 metres or more, including when working on fragile surfaces.

People:

All employees and contractors who are required to work at height must be trained and competent. Having:



The ability to **identify the hazards** associated with, and during, work at height.



Appropriate methods to **secure tools and objects** to prevent them from falling.



The operation of work at height **equipment** e.g. MEWPs, tower scaffolds, work cages, ladders, etc.



Awareness of surroundings, surfaces and maintaining the **safety of others** in the area.



Emergency response and rescue procedures, including rescue of a suspended person connected to fall-arrest equipment.



The use of **fall-arrest equipment** including: pre-use inspections; selection of suitable anchor points; what to do if a suitable **anchor point** is not available; use of harnesses and the fitting of self-retracting lines.

People:

Task Risk Assessments must be performed continually to identify all the hazards of working at height; considering both the risks to those working at height and to people working in the surrounding environment, who may be struck by falling objects.



The risk assessment must consider the following hierarchy:

Can you **avoid** work at height? E.g. using extendable tools from ground level to remove the need to climb a ladder; installing cables at ground level; lowering a lighting mast to ground level or ground level assembly of edge protection.

Where work at height cannot be avoided, can you **prevent** falls using either an existing place of work that is already safe, or work equipment? E.g. mobile elevating work platforms (MEWP), tower scaffolds or a work restraint (travel restriction) system that prevents a worker from getting into a fall position.

Can you **minimise** the distance and consequences of a fall, by using the right type of equipment? Practical examples of collective protection include: safety nets and soft landing systems. Examples of personal protection include: industrial rope access and fall-arrest systems using a high anchor, etc.

Process:

Sites must ensure that during working-at-height activities the following controls are in place:

Works on the **edge of open hatches** will only be performed after a ship's **handrail** is installed. If it's not possible to install the guardrail, workers who have to go close to the edge of open hatches should wear a **safety harness** attached to structures of the vessel or other approved anchor points.

Vessel **gangways** must be fitted with **nets** and secured.

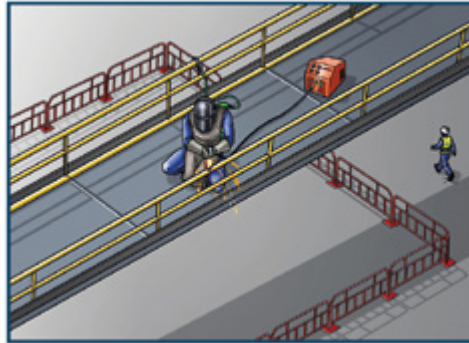

Provide **exclusion zones** below works at height if there's a risk of falling objects. E.g. dropped tools or materials or molten metal from welding activities.



A **double lanyard** must be used where work requires the person to move through detaching and reattaching lanyards.

Equipment

Safety Cage equipment requirements

Working at height **equipment** is **inspected** and **maintained** in a safe condition with maintenance records and test certificates.

When using **Safety Cage** and other **employees lifting** platforms

1. The cage must be secured by connecting to the spreader with twistlocks and double locks.
2. Safety cage users must wear a harness and be attached to an anchor point inside the cage.
3. If attached to a crane with people inside, the crane's speed must be reduced to a maximum of 25%.
4. Twistlock poles must be attached to cages to prevent them from falling.

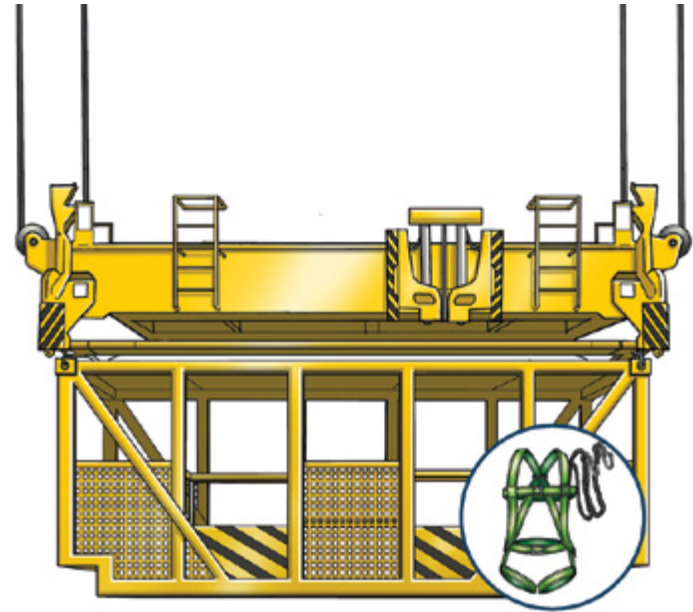

Equipment

When using MEWP/scissor lifts:

1. Operators must be certified.
2. Personnel must wear a harness and lanyard and attach it to a certified anchor point.
3. Guardrails must be in place.
4. The platform must be lowered before moving.



Equipment

When using ladders:

1. Only for short duration works / estimated less than 10min
2. Place on stable ground and at a 75° angle.
3. Extend at least 1 meter above landing place.
4. They must have nonslip footing and tied at top.



1. They must be secured or supported by a third party
2. They should be inspected before use.
3. ALWAYS maintain 3 points of contact.

Equipment

When using scaffolding (fixed and tower):

1. It must be designed, anchored, erected and tagged by a competent person.
2. Guardrails and toe-boards must be in place.
3. Access ladder must be from inside the scaffold—avoid external ladders - access locked at end of work shift.
4. Tower scaffolds must be used and secured on an even surface.
5. Inspected regularly - at least once a week.
6. Mobile scaffolds must be cleared of people and materials before moving.
7. Don't use ladders on top of scaffolds.
8. Don't use mixed scaffold equipment together.
9. Don't erect, modify, move, perform maintenance on, inspect or dismantle scaffold in windy conditions.

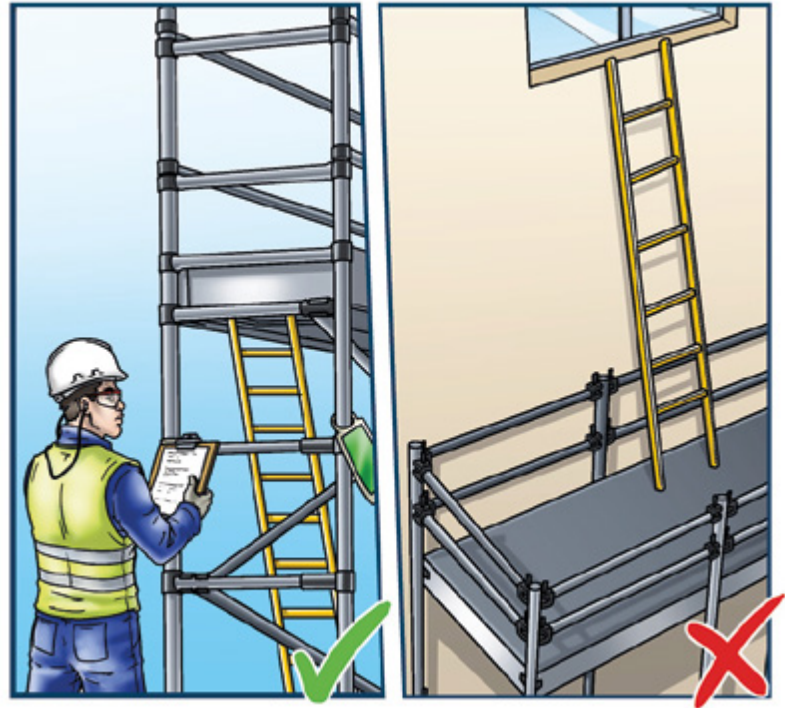

Equipment

When using fall prevention and protection equipment:



1. Perform pre-use inspections on harnesses, lanyards, anchor points, etc.
2. Maintain and store according to manufacturers' instructions.
3. Test and tag every 6 months, or more frequently, if required by local legislation.
4. Always connect to a secure anchor point or static line.
5. Ensure lanyards are the correct and safe length for your task.
6. Body belts are not allowed to be used.

4. Personal Fall Protection Equipment (PFPE)



Dangers:

Not understanding how to correctly calculate the fall clearance when using fall protection equipment.

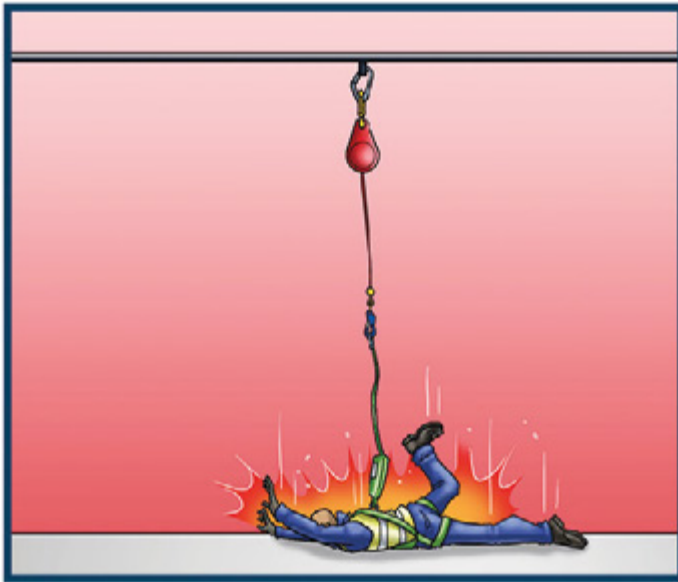

Choosing the wrong fall protection equipment to use when working at height.



Critical Controls:

There are two types of fall protection equipment:

1. Fall restraint – stops you from reaching the edge of a platform. Fall restraint lanyards stay the same length.

Only use full-body harnesses with personal fall protection equipment in compliance with EN 361:2002 or other similar internationally recognised standards.

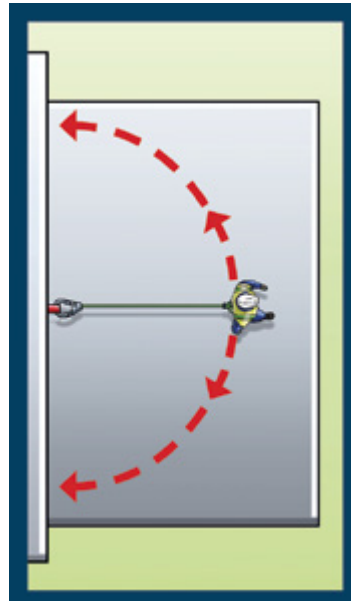

Using PFPE should be considered only as a last resort. Using safer (higher) controls, such as working from safe scaffold platforms, should be considered before PFPE.

Critical Controls:

There are two types of fall protection equipment:

2. Fall arrest – stops you from hitting the ground.

Fall arrest harnesses must have:

- suspension trauma straps, and workers must be trained in their use; and
- shock absorbers, no more than 2 metres, to help absorb the kinetic energy and reduce injury.



Lashing eyes and twistlock pockets are rated more than 15kN and can be used as anchor points.



Develop emergency response and retrieval plans for all identified scenarios, in consultation with workers and person in charge (PiC).



Critical Controls:

You must be trained and competent before using fall protection equipment. This includes knowing:

- the 2 x 2 rule for when to wear fall protection equipment – if there's a risk of falling more than 2 meters within a 2 meters unprotected edge
- how to choose equipment you need for the task – fall restraint/fall arrest
- how to work out fall distance and the pendulum effect
- how to identify appropriate anchor points.

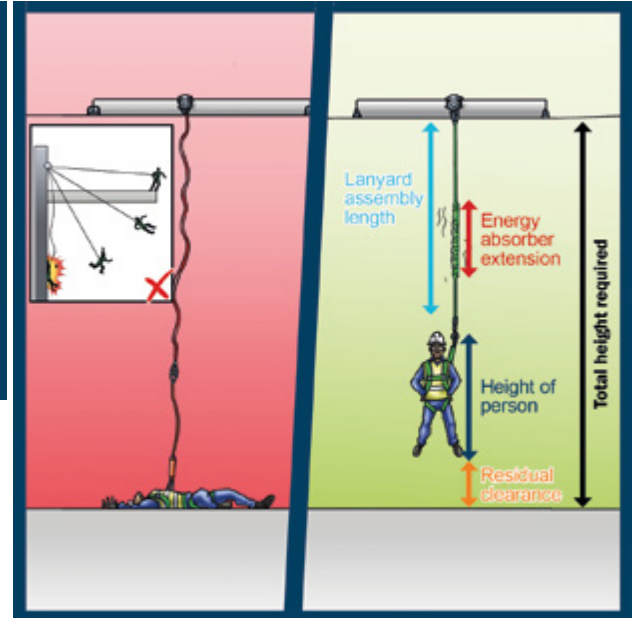
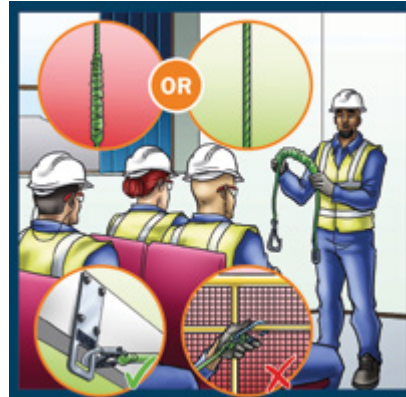

Critical Controls:

Always use double lanyards with heavy duty snap hooks when required to transfer while working at height.

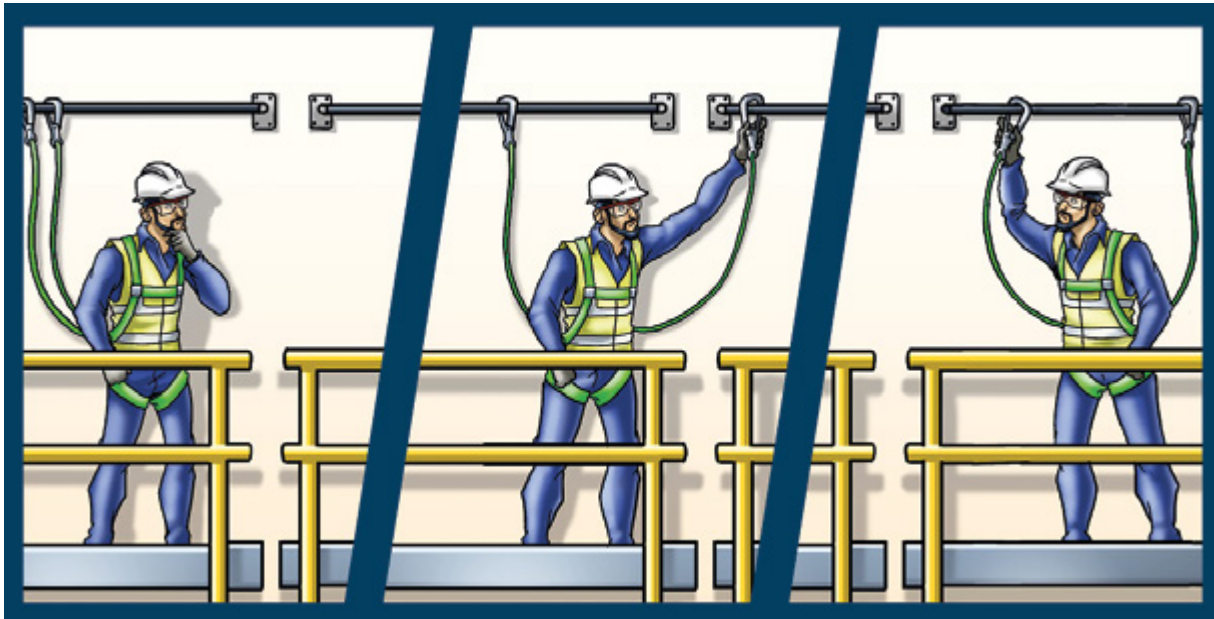

Critical Controls:

A competent person must inspect and record fall protection equipment every 6 months.



Line management also needs to be trained on fall protection equipment so they can check that it's being used correctly.



Critical Controls:

Never use fall prevention lanyards (which have shock absorbers) with inertia reels.

Never use twist lock hooks. Only use tri-lock or Karabiner hooks. Anchor straps must have a capacity of at least 22kN.

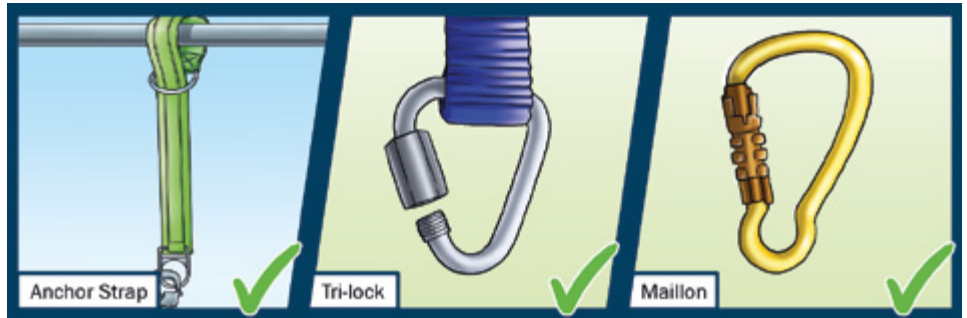
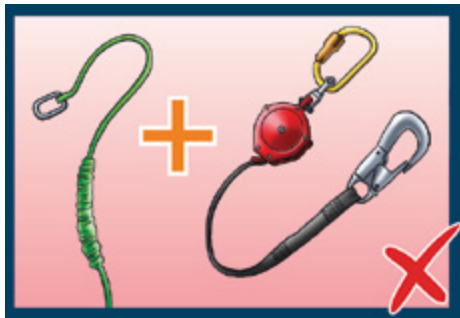

5. Stored Energy

Stored energy can come from any number of sources including:

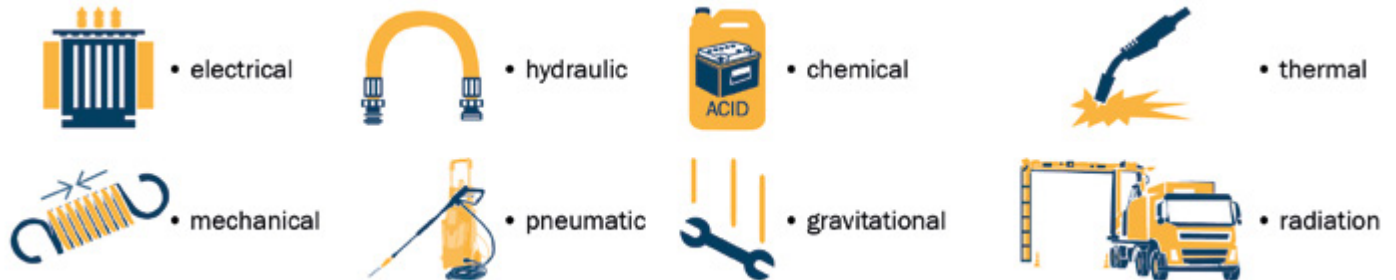

People:

1. **Specific roles** for employees with responsibilities for isolation are defined, documented and agreed to;
2. Employees and contractors who undertake any form of isolation are:
 - **trained and competent;**
 - have their competencies regularly **assessed;** and
 - **updated** on any changes to isolation systems that could affect their work.



People:

All employees who work with or around equipment that may be locked or tagged out must have **training based on the level of risk.**



Process:

Risk Assessments must be performed continually to identify all the hazards of working with and around uncontrolled energy sources.



Establish and maintain an isolation register for all known isolation points. Terminal must have documented isolation and lock out/tag out (LOTO) processes for all equipment and activities, especially equipment with one or more energy sources.



Process:

A verification step must be considered into processes to ensure the energy sources have been isolated. E.g. using a voltage meter to check low voltage electrical isolation, always test for dead.

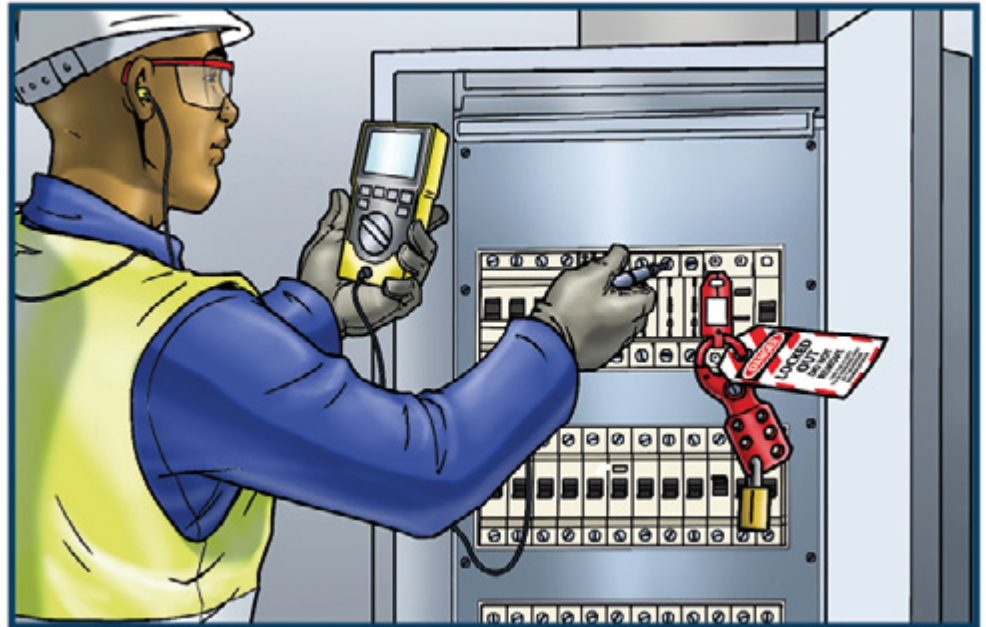

Process:

specific procedures are developed:

- to lessen exposure where it is not possible to fully isolate stored energy;
- for isolation involving more than one person;
- for the transfer of isolation between personnel and shift hand-overs;
- for working with split rim multi piece assemblies;
- for working with mooring lines; and
- for working with high voltage (HV).

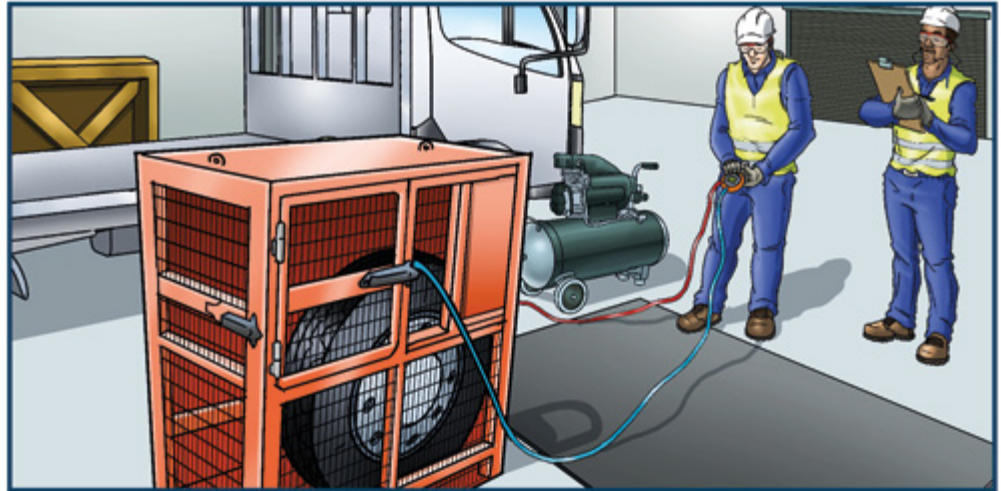

Process:

Isolation procedures must be reviewed periodically (at least every 12 months). This must be done when there are:

- changes to process conditions;
- purchase/installations of new equipment;
- modifications to existing equipment; and
- internal and external incident findings and learnings.

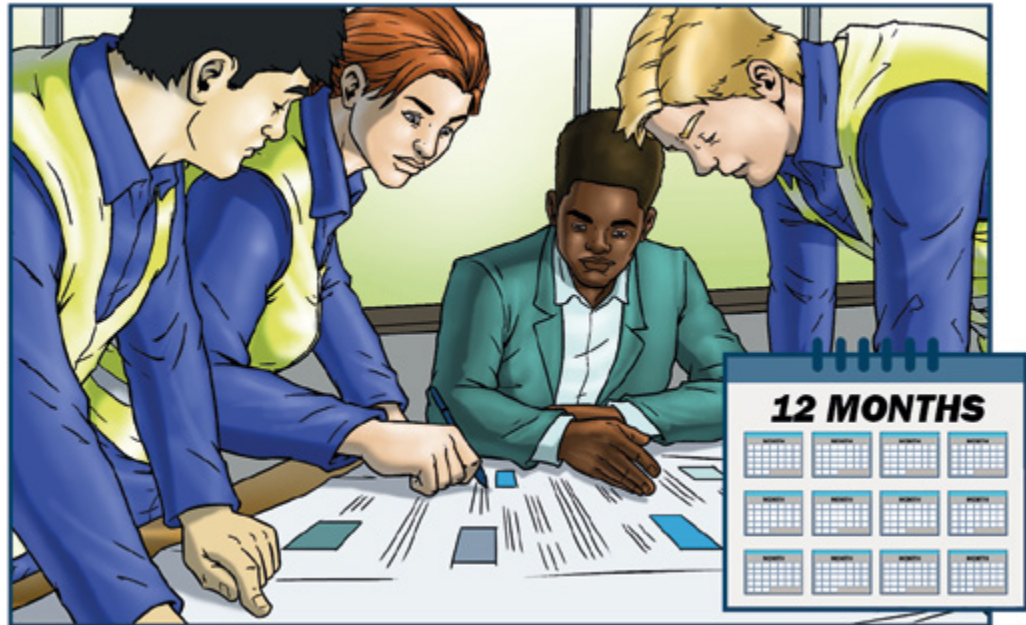

Equipment

Before being used on site, all hired and contracted equipment is reviewed to ensure it meets site isolation requirements.



Equipment

- Documented isolation and lock out/tag out (LOTO) processes available for all equipment and activities, especially equipment with one or more energy sources
- All electrical cabinets are locked and all high voltage installations, such as sub stations, are locked and restricted.

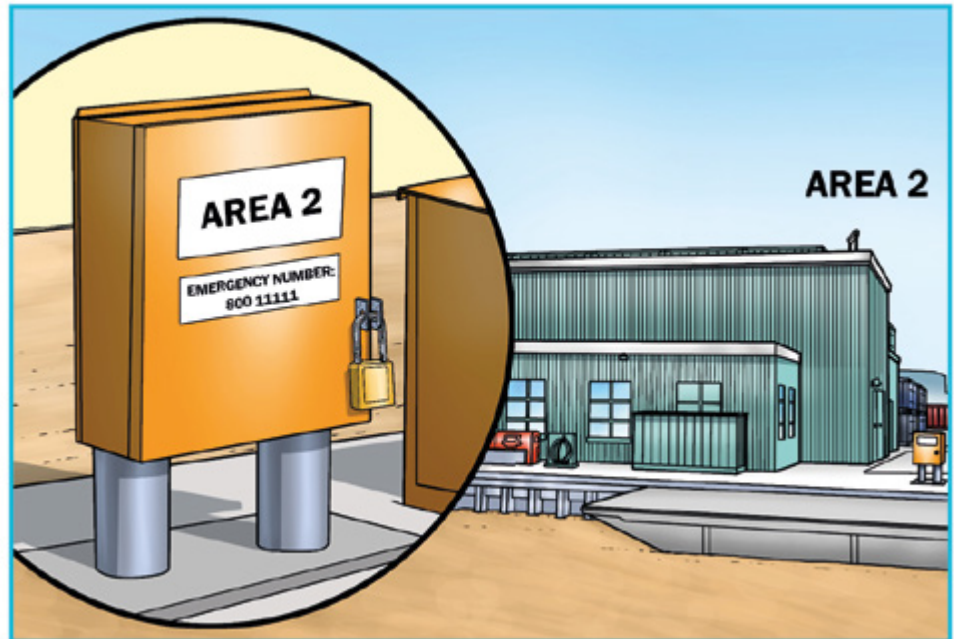

Equipment

All tags and locks are clearly labelled to identify the person and type of work.



6. Control of Contractors



People

Employees who have responsibilities under the **Contractor Management Plan** must be **trained and competent**. Competence and permits must be **checked** before work commences.



People

Terminal must ensure all contractors:

- are trained and competent;
- have the right permits; and
- licenses for the plant and equipment they operate
- are briefed on terminal risks, and where they are permitted to work



Process

A terminal representative is appointed to manage each contractor or contract.

All sites must have and maintain a list of approved contractors.



Contractor safety capabilities and performance, must be reviewed systematically during the year, including previous performance such as injuries rates, improvements and initiatives, risk management approach, incident management, safety or environmental records and reference checks.

Process

Before talking to or appointing any new potential contractors, sites must define the scope of work and performance criteria. This must include relevant:

- hazard identification
- risk assessments
- risk control measures



Process

The contractor need to be provided with information on the hazards and controls of the work. If this is not possible, for example due to emergency works, the contractor must be supervised by Terminal competent resources.



Process:

Sites must develop a contractor management system to ensure:



- give the contractor an opportunity to identify hazards and review relevant risk management materials



- Have a specific contractor induction / orientation training program



- defined formal and regular communications with contractors in place



- contractor performance monitoring



- formal/defined actions for poor contractor performance



- contracts include commercial consequences, based on safety and environmental performance, such as penalties, bonuses or contract termination



- management of hazardous materials, prevention of soil contamination and spill response



- correct waste disposal



- emergency response procedures are in place

Equipment:

Equipment used by the contractor must be **fit for purpose, regulatory maintained, checked and authorized** by an authorized person before being allowed onto the terminal.

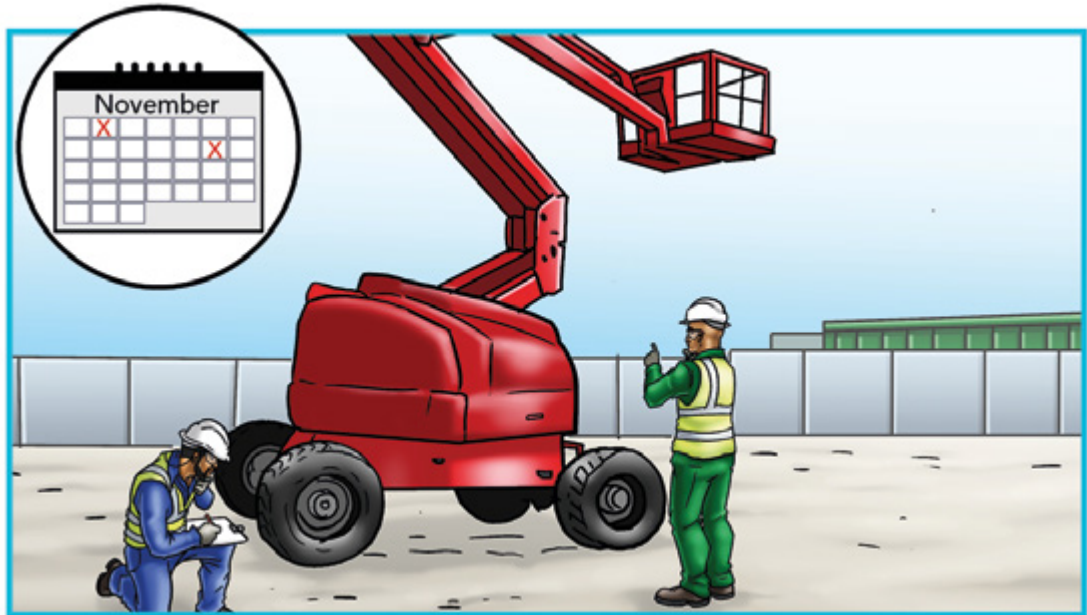

Equipment:

Contractor equipment must comply with OEM requirements.

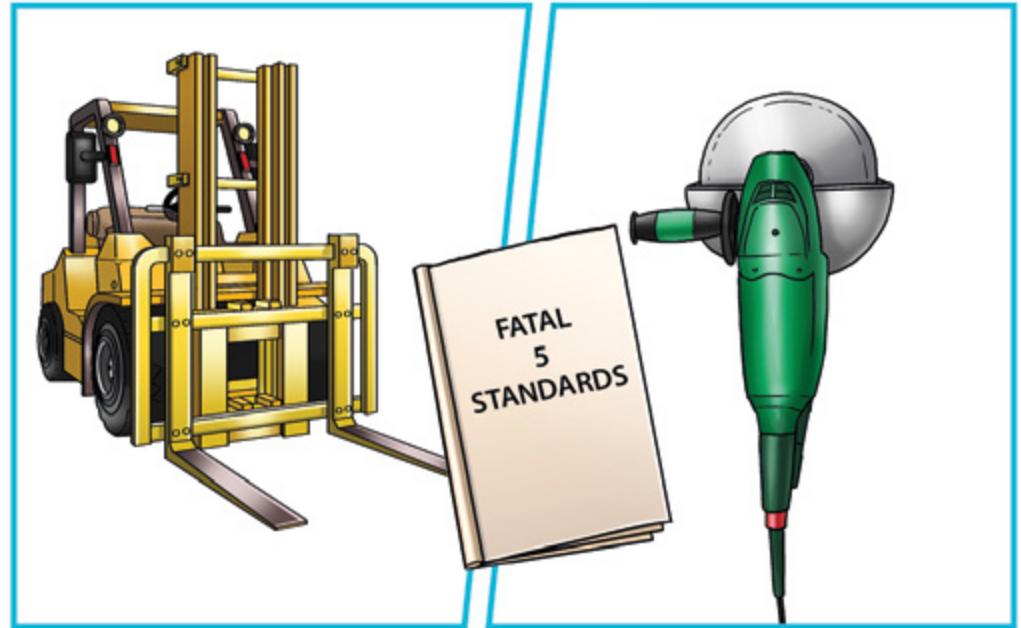

7. Conducting a Vessel Safety Inspection

Dangers:



Vessel Safety Inspection

Before a vessel docks, log onto the APMT Vessel Inspection portal and check the latest report for safety critical defects as proactive learning.

Communicate any known safety defects to the lashing crews / employees at the pre-start meeting.

Before boarding the vessel, the gangway must be correctly landed with safe access and meets regulatory requirements. All gangways are rated to carry a maximum number of workers.

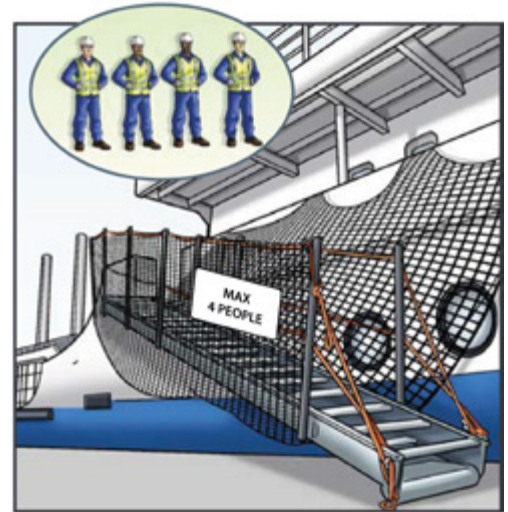

Vessel Safety Inspection

The VSI performer can invite the Vessel Representative to participate in the inspection. Working areas shall be inspected first.



The VSI performer will assess safe means of accessing containers, cargo, holds or lashing platforms on board the vessel before work commences in that area.



Vessel Safety Inspection

The VSI performer shall escalate defects that pose a risk immediately to the Senior Vessel Representative. Record defects using the APMT Vessel Inspection App. Inform the Senior Vessel Representative immediately of any concerns. People working on board the vessel must be informed about the hazards identified. Depending on the hazards identified, work shall be restricted or not commence until made safe.

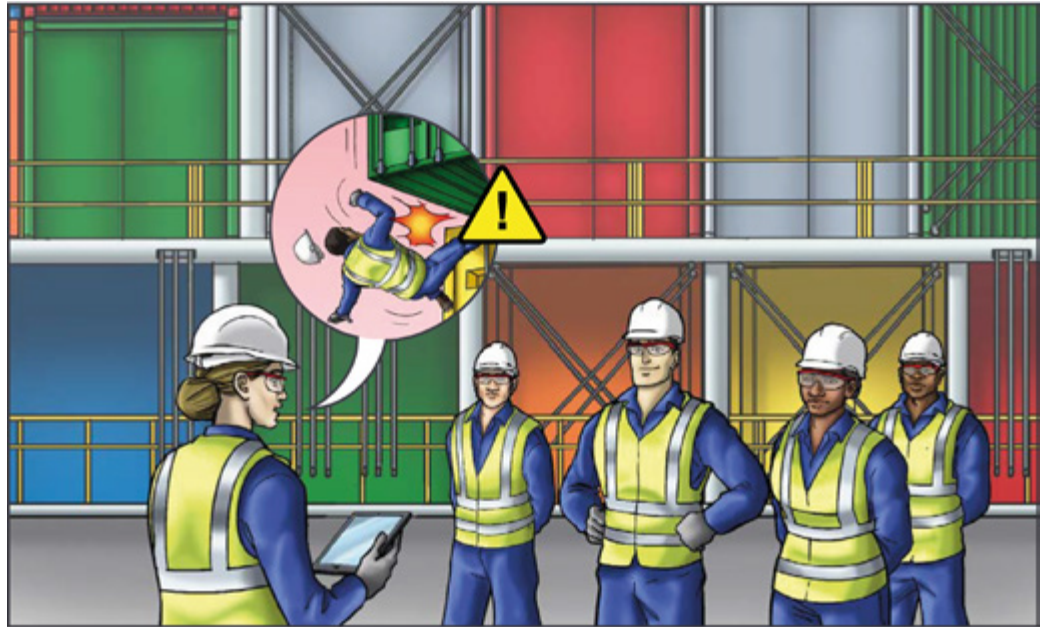

Vessel Safety Inspection

Ensure housekeeping standards are maintained at all times and loose items, such as lashing equipment and other cargo securing devices, are removed before lifting hatch covers.



Vessel Safety Inspection

Once the vessel inspection has been completed, agree on the findings with the Senior Vessel Representative. Collaboration to make the vessel call safe is something to celebrate.



Vessel Safety Inspection

Log onto the APMT Vessel Inspection portal and send the report to the vessel.

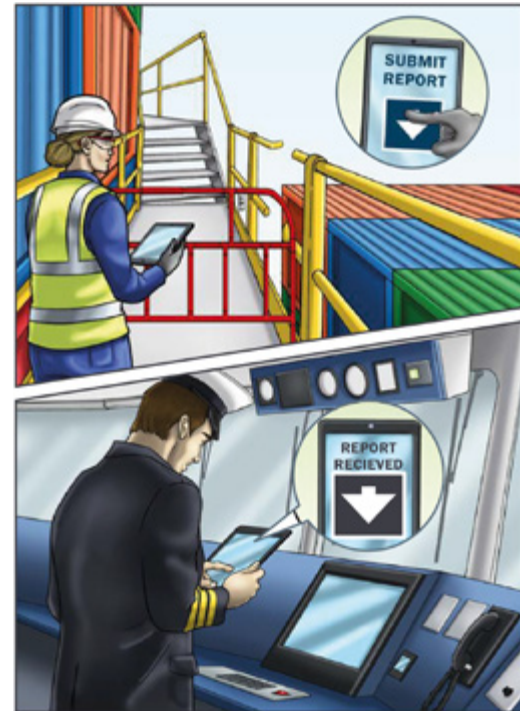

APMT and MAERSK shall:

For all Maersk and Chartered vessels that require escalation, log on to the Vessel Inspection portal and use the email addresses provided; CC the Liner Operating Center (LOC). For all other lines, always escalate via the agent and LOC.

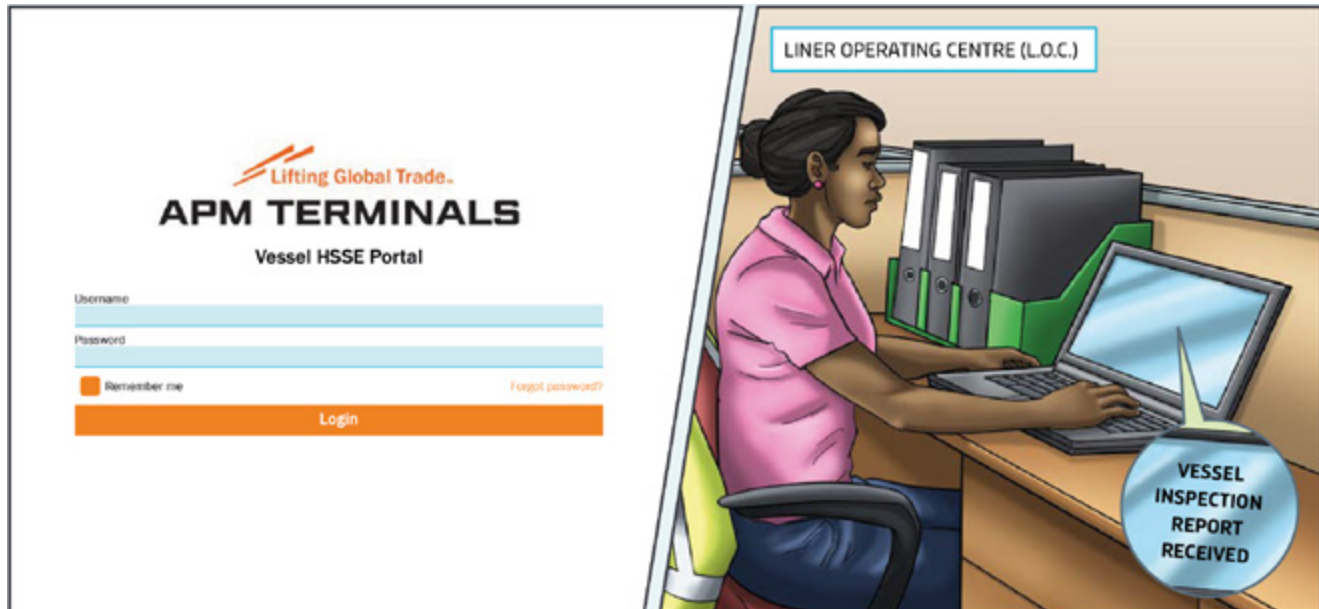

8. Vessel Inspection Engagement Agreements

APMT and MAERSK Agreement

Engage with respect. Assess any risky issues that might impact safe work. Agree on issues and any fixes together. Ensure the access, area and fall protection is safe for lashers. Escalate by agreeing first what to do and then referring to the escalation guide.

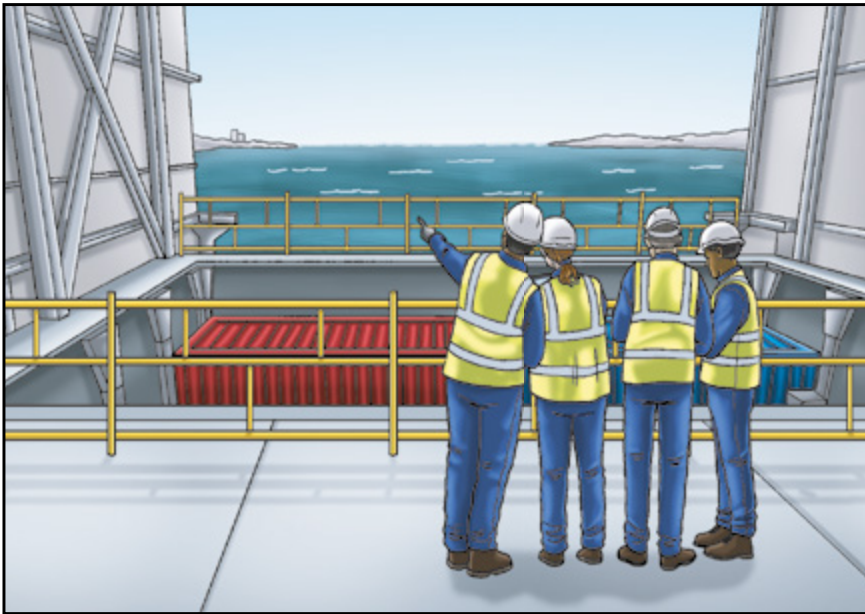

Be aware

Ensure you know the process and how to engage, assess, agree and ensure the work area is safe together.



Have respect

Meet, greet, agree and thank each other, vessel arrival time is busy and no one wants anyone to be hurt.



Engage

Discuss any issues, and agree on any temporary fixes and escalations together. Do not do this alone.



Make safe

Confirm the area is safe before allowing work to proceed.

APMT and MAERSK Agreement

Be aware that the inspection is shared between the vessel and terminal:

- Engage positively with each other - success depends on all parties working positively together.
- Share knowledge - everyone wants to work safely. Knowing about possible issues in advance can help this process.
- Terminals are very busy places with many ships arriving and departing. It is important to prioritize a meet, greet, discussion of issues and thank you as a minimum.



Accept that temporary fixes and barriers that ensure safe work for lashers is okay. Permanent fixes are not always solved quickly.



Aim to plan early by assigning roles, ensuring availability, checking previous reports and making vessel areas and access are safe.



Ensure all parties are trained on vessel inspection and safe work requirements.

APMT and MAERSK Agreement



The purpose of the inspection is to ensure the lashers can work safely, rather than a perfect vessel. Discuss and agree on the risks, issues, fixes and any escalations together.



Terminals are busy places with many operational pressures, but it is vital that work areas are made safe. Anyone has the authority to stop work until any risks and safety measures have been addressed.



9. Lashing Personal Protective Equipment

Dangers:

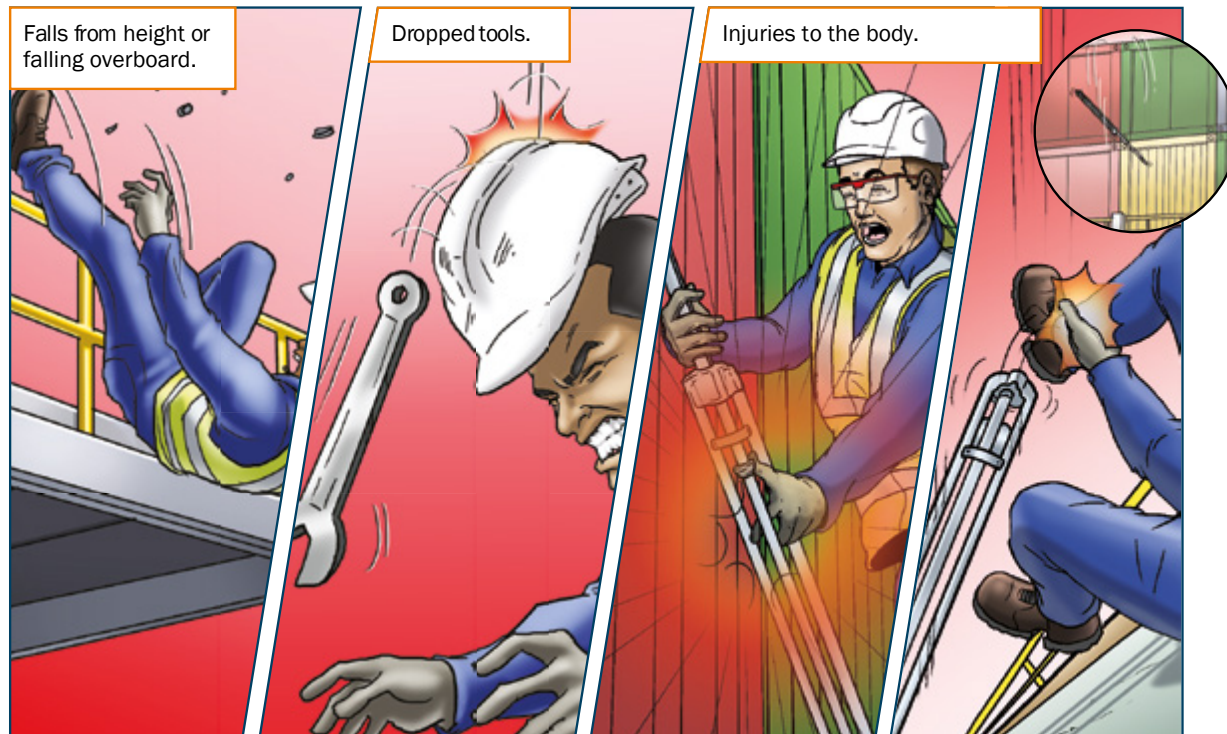

Lashing PPEs

To reduce the seriousness of any potential injuries, it is vital that you have the right personal protective equipment (PPE) when performing lashing work, and that you know how to use it correctly.

Always wear the minimum PPE requirements for the job:

- High-vis jacket/vest with reflective strips
- Hard hat with reflective strips
- Ankle boots with toe-protection
- Tight-fitting, impact protection gloves
- Tear-resistant trousers (reflective strips optional)



Lashing PPEs

Some PPE is situation-specific, depending on Risk assessment findings

When working at height or in a safety cage, wear:



- Fall harnesses and lanyards (see W@H VWI)

Always ensure all PPE is in good condition.



10. Lashing Workplace Risk Assessment

Lashers:

Perform this quick Risk Assessment before working in a bay or catwalk to ensure it is safe.

1. Check ladder conditions.

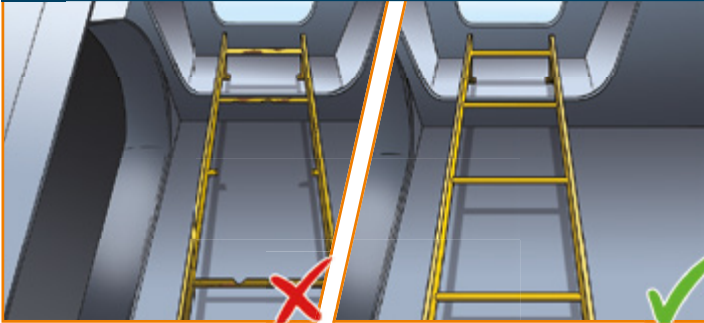

2. Check for and close any open manhole covers.



Lashers:

3. Check walkways are free from lashing materials.

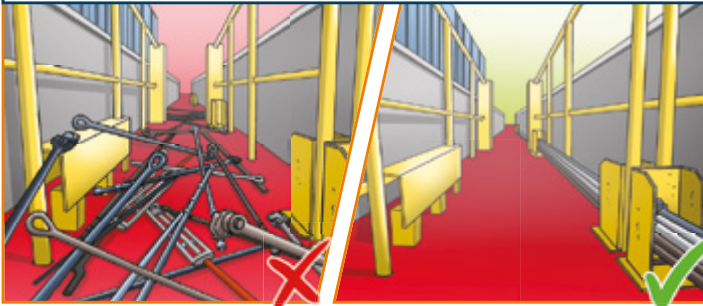

4. Check for any poor or missing fencing where a fall of >2m could occur e.g. outboards and open hatches.

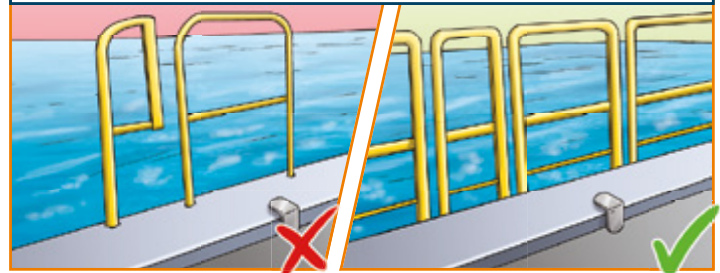

Lashers:

5. Check for heavy corrosion on walkways, railings and manhole covers.

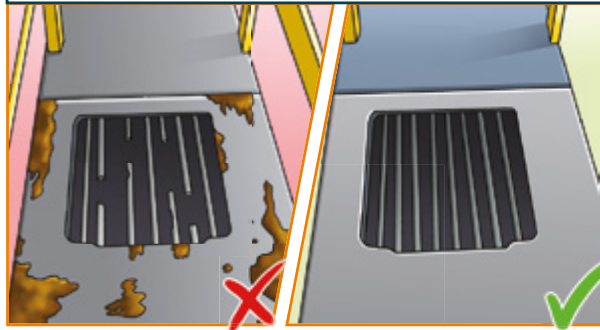

6. Check for spills and leaks, especially of harmful substances.

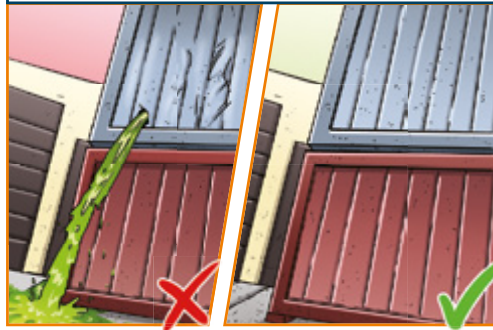

Lashers:

7. Check reefer cables are not causing a trip hazard or are damaged.

8. Is there enough light to work?

Report any defaults to your lashing coordinator to get fixed.

Lashing Supervisor/Lashing Foremen:

Perform this quick Risk Assessment before working in a bay or catwalk to ensure it is safe. Ask yourself:

1. Do I have enough personnel to perform the work?

2. Do I have any inexperienced personnel that need extra supervision?

Lashing Supervisor/Lashing Foremen:

3. What are the weather conditions?

4. Are there any special working requirements or hazards identified from the current or previous vessel inspections?

Lashing Supervisor/Lashing Foremen:

5. Is there enough time to complete the work safely?



Report any concerns to your vessel command.

11. Lashing Equipment Housekeeping

Dangers:

1. Falls from height or falling overboard.



2. Dropped tools.



3. Personal injuries.



Proper storage of lashing equipment

Performing lashing work in an untidy area and around ships' holds and on the docks can lead to slips, trips and falls or even fatalities.

1.

Keep lashing walkways free of lashing bars, reefer cables and turn buckles.

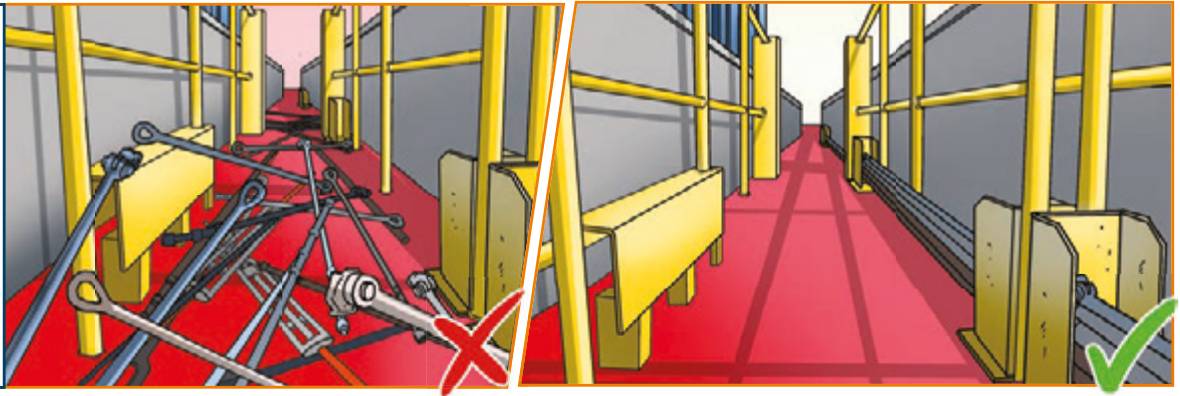

Proper storage of lashing equipment

1. Deck walkways must be clear of obstacles and other trip hazards (lashing materials, cables, etc).



2. To allow for safe circulation, keep deck areas clear of lashing equipment like stairs, twistlocks, lashing spanner on the deck.

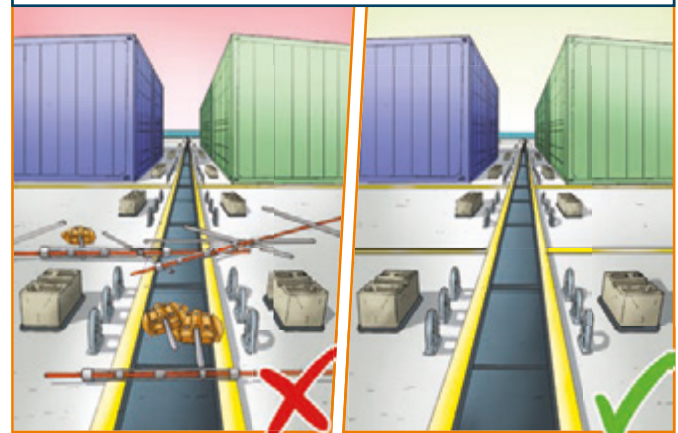

Proper storage of lashing equipment

3. Keep manhole covers free of loose objects to prevent injury and dropped object hazards.

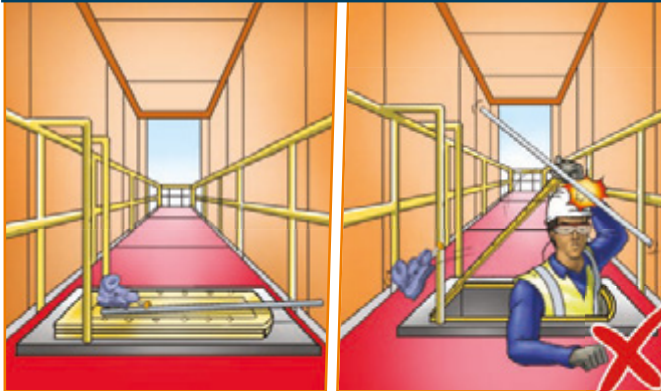

5. Manholes and gravity bars are closed as soon as you have gone through them.

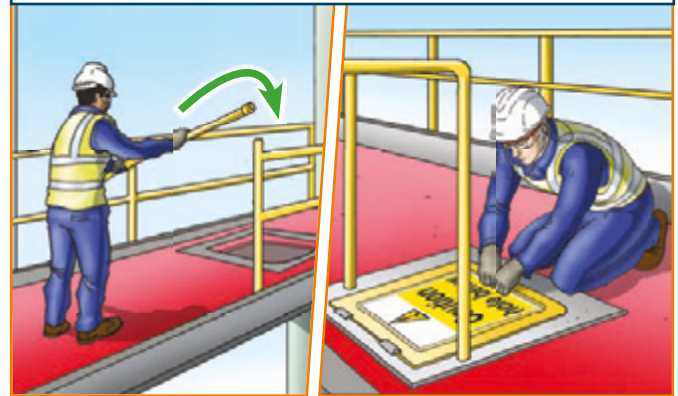

Proper storage of lashing equipment

6. Keep hatch-covers free of loose objects and confirm clear before any lift to prevent falling objects.

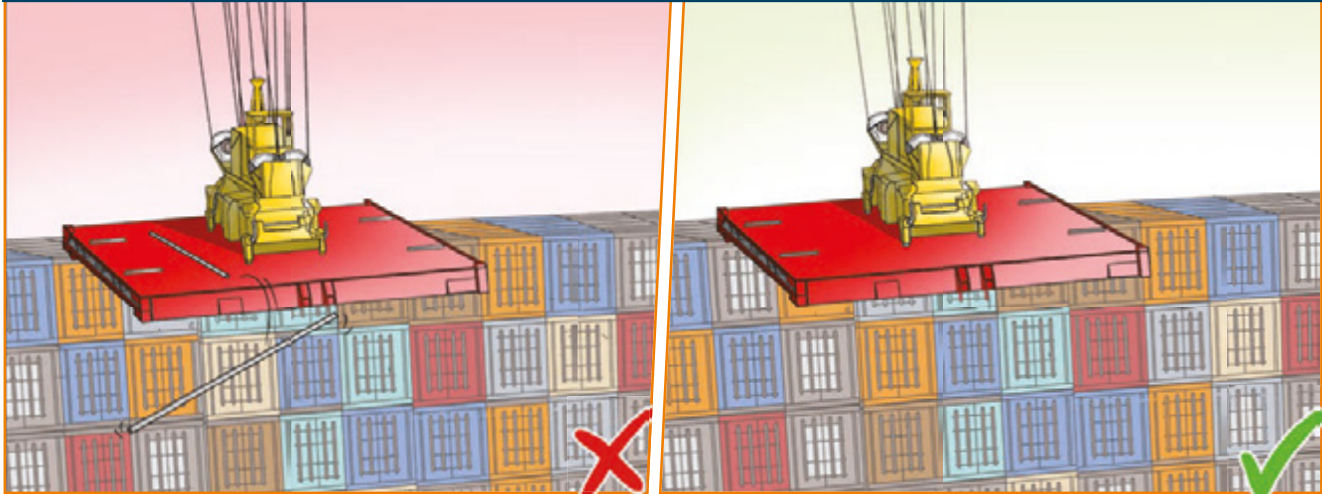

Equipment Bins

Twistlocks should always be stored in gear bins. Damaged, broken, corroded and poorly maintained twistlocks should be stored in the **RED** defect gear bins and separated from functioning twistlocks. Gear bins should be well maintained and not damaged or corroded.

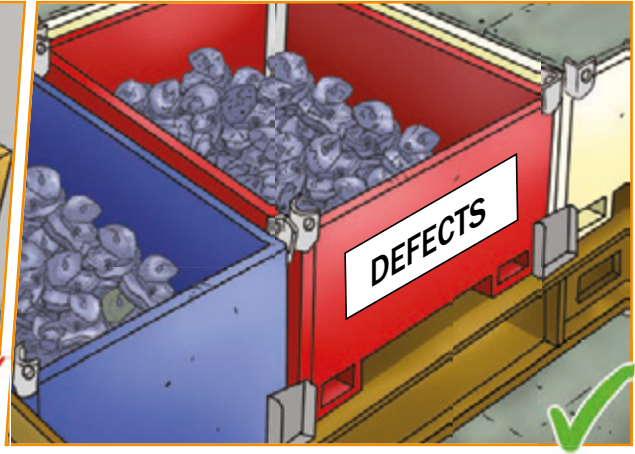
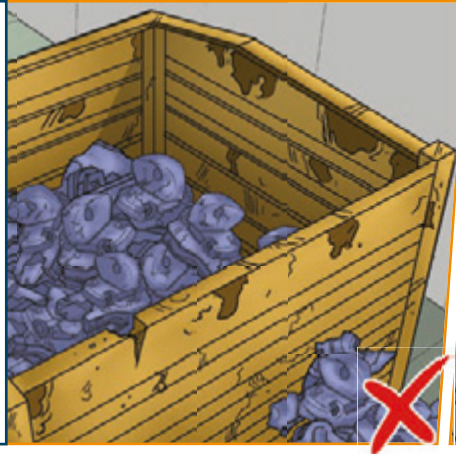

12. Three Container Separation

Dangers:



Dangers:

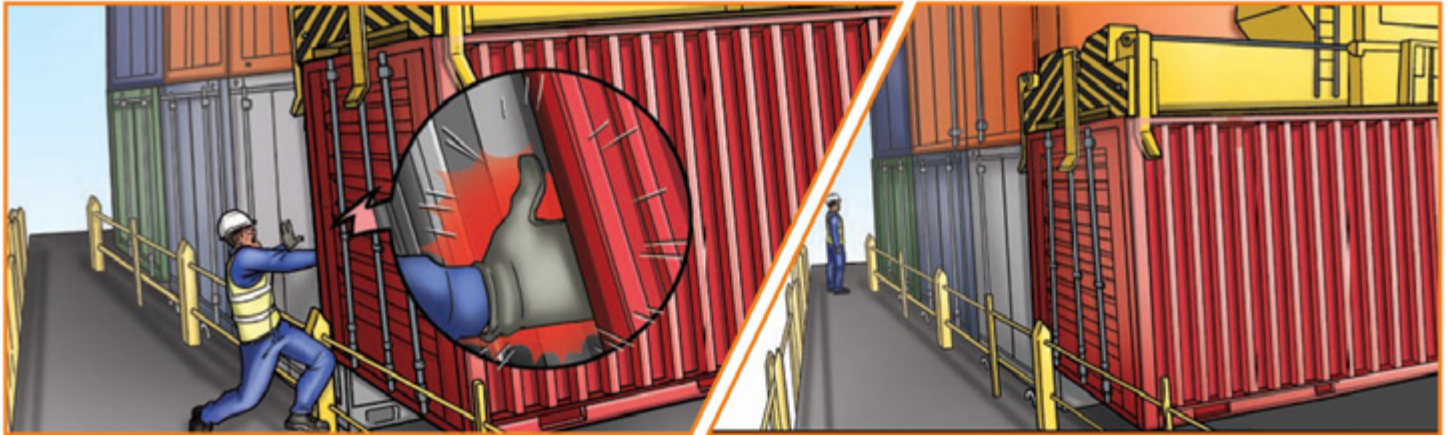

Dangers:



Three container separation rule:

Working near containers being moved, lifted, and/or lowered on a vessel can be extremely dangerous, especially when standing too close or not being fully aware of what's going on around you.

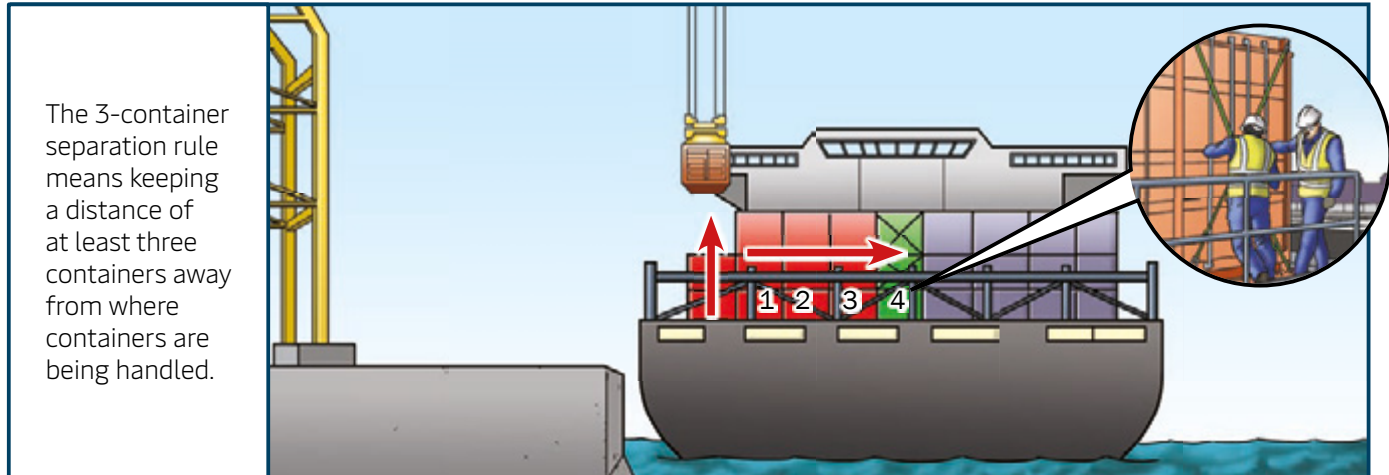

Three container separation rule:

When unlashing, 3-container separation is best achieved by unlashing from inside to the outside. The crane operator must wait for the first 3 containers to be unlashied before lifting the first container.

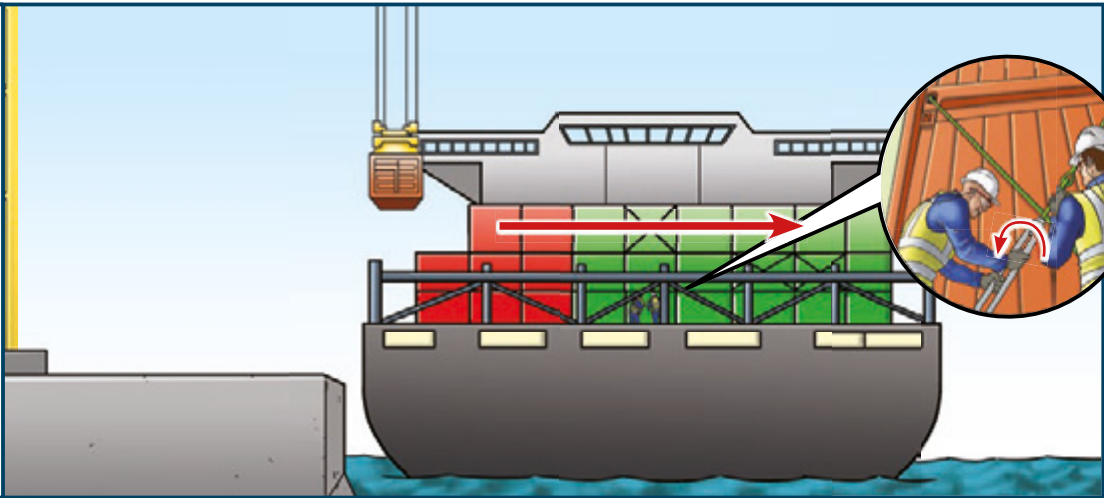

Three container separation rule:

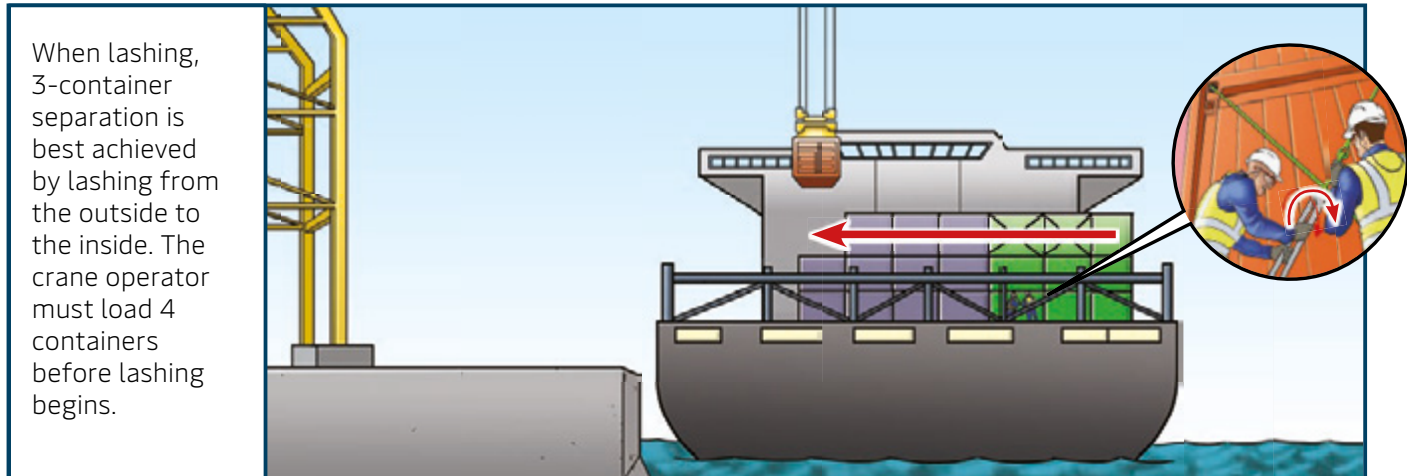

Note: Please refer to the Visual Critical Controls titled “Working in Pairs” for further safety instructions when lashing and unlashng.

Communication is critical

Keep an eye out for your buddy at all times. If they are no longer keeping a distance of three containers away (3-container separation), stop them and get them to a safe position.

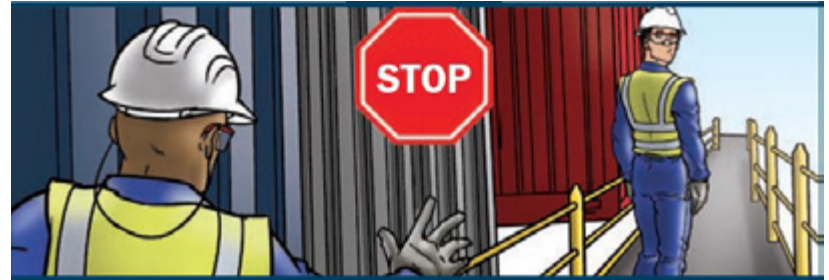

Inform your lashing foreman of issues, such as an unusual loading/discharge pattern.



13. Lashing Twistlock Troubleshooting

Dangers:

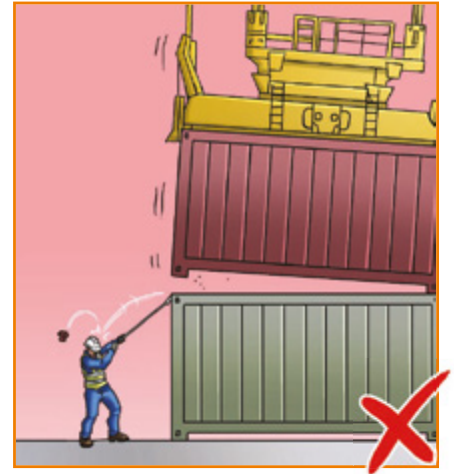

Jammed Twistlocks

Sometimes twistlocks can become stuck, because of damage (e.g. broken handle/pig-tail) or poor maintenance (e.g. greasing). This means that you will have to use certain tools to unlock it to free the container.

It is the responsibility of the vessel master for twistlocks and other lashing equipment to be in working order. Time taken to troubleshoot a stuck twistlock is not included in productivity calculations. If a stuck twistlock can't be safely released, tell your foreman/supervisor and escalate the issue back to vessel command to resolve.

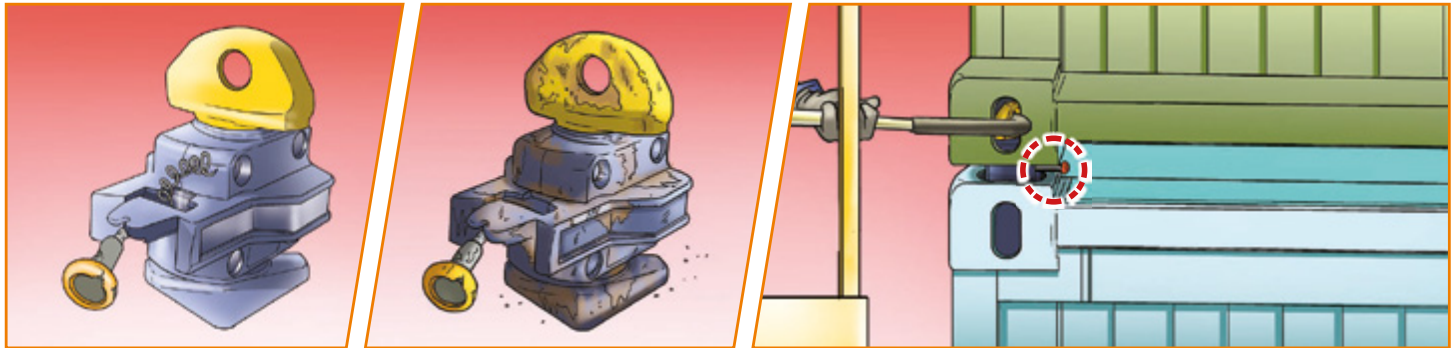

General good practices when unlocking stuck twistlocks:

Ensure your emergency tools for unlocking twistlocks are in good working order.

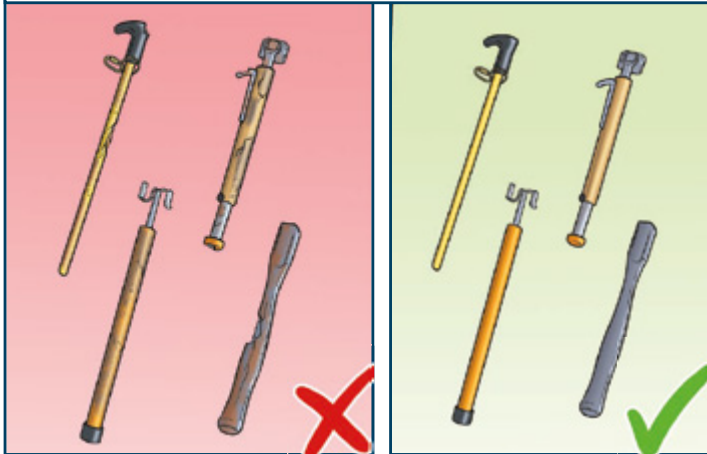

Check the area where you'll be working is free of any obstructions, tripping hazards, and damage.

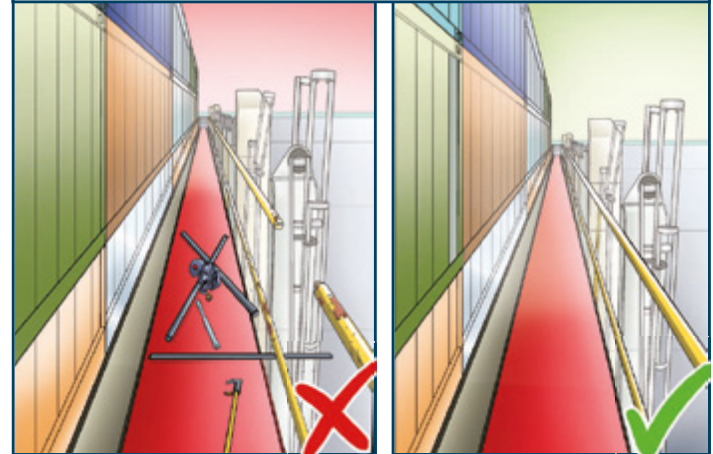

General good practices when unlocking stuck twistlocks:

Always work with someone so they can help you.

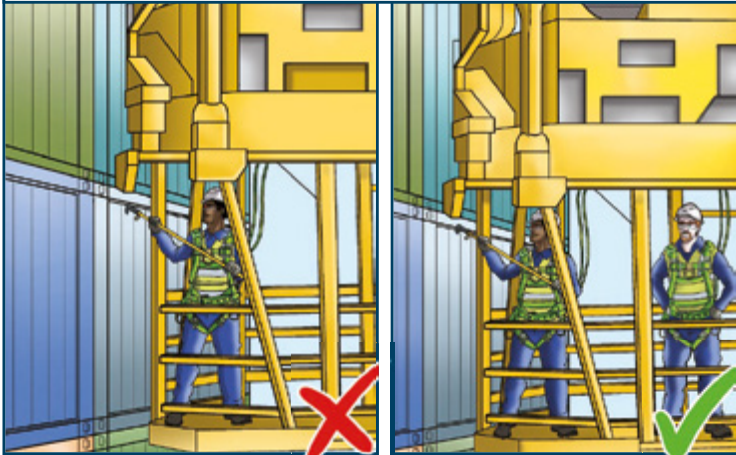

Never work under lifted cargo.

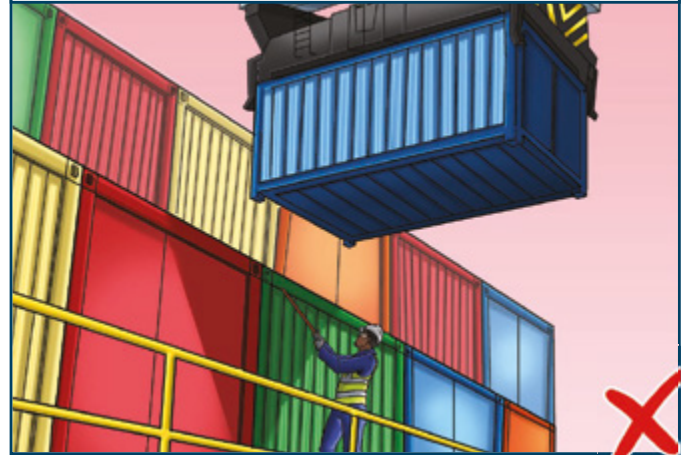

General good practices when unlocking stuck twistlocks:

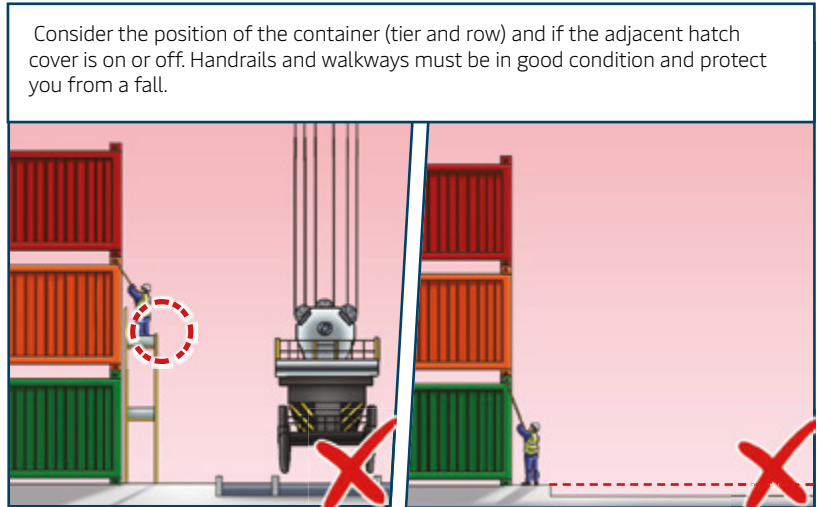

General good practices when unlocking stuck twistlocks:

When a stuck twistlock CAN be reached from the lashing bridge/walkway using the emergency tools...



Wear standard PPE and only work from a protected lashing bridge / walkway

Ask the foreman and prepare the proper twistlock emergency tools.



General good practices when unlocking stuck twistlocks:

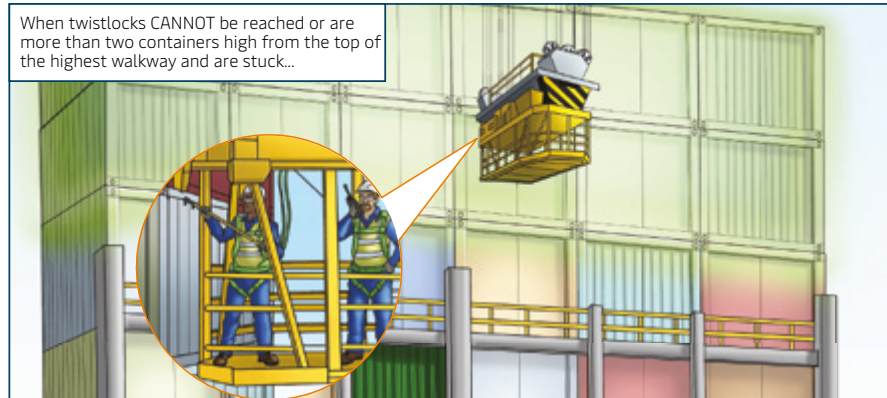

Ask foreman for lashing cage and twistlock emergency tools.

Wear working-at-height PPE, which includes a harness and lanyards.



General good practices when unlocking stuck twistlocks:

The lashing cage must be secured to the spreader with secondary attachments before it is lifted with people inside. During high winds, lightning or other unsafe weather conditions, work must be stopped, including all work at height.



Note: please refer to Working at Height Visual Work Instruction.

General good practices when unlocking stuck twistlocks:

Stuck twistlocks that cannot be safely accessed from a deck position must be accessed via a lashing cage:

If the stuck twistlock can't be accessed via a lashing cage due to its position or lack of space between bays; you may need to clear the adjacent stack of containers, or the containers opposite in the next bay. This will allow the lashing cage to be positioned to allow access to the stuck twistlock using rescue tools. The area below must be cleared of people and the Person in Charge (PIC) must direct the operation from a safe position.

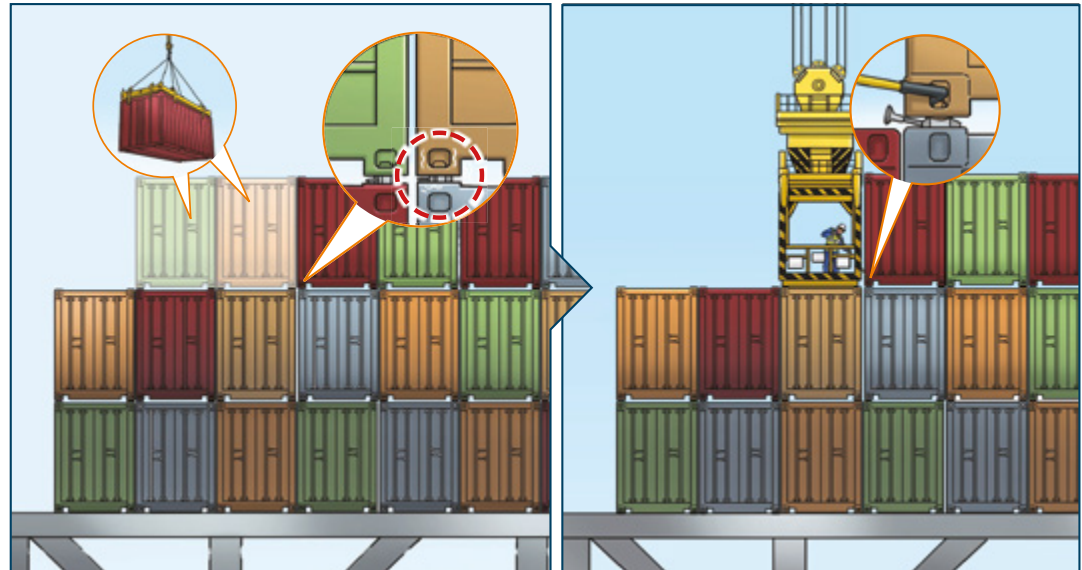

General good practices when unlocking stuck twistlocks:

A Person in Charge (PIC) must oversee the stuck twistlock troubleshooting and give orders to the crane operator using a radio. They must also ensure the area where troubleshooting is taking place is cleared and that they are positioned in a safe location with a clear line of sight.

The higher an object falls from, the more dangerous it is if it hits someone.

If your site has a risk assessed process for releasing stuck twistlocks that involves pulling on the twistlock while the spreader gently lifts the stuck container, then this may only be done at one container high above the lashing platform. This is a high-risk activity during which you are unable to maintain 3-container separation and other critical safety measures.

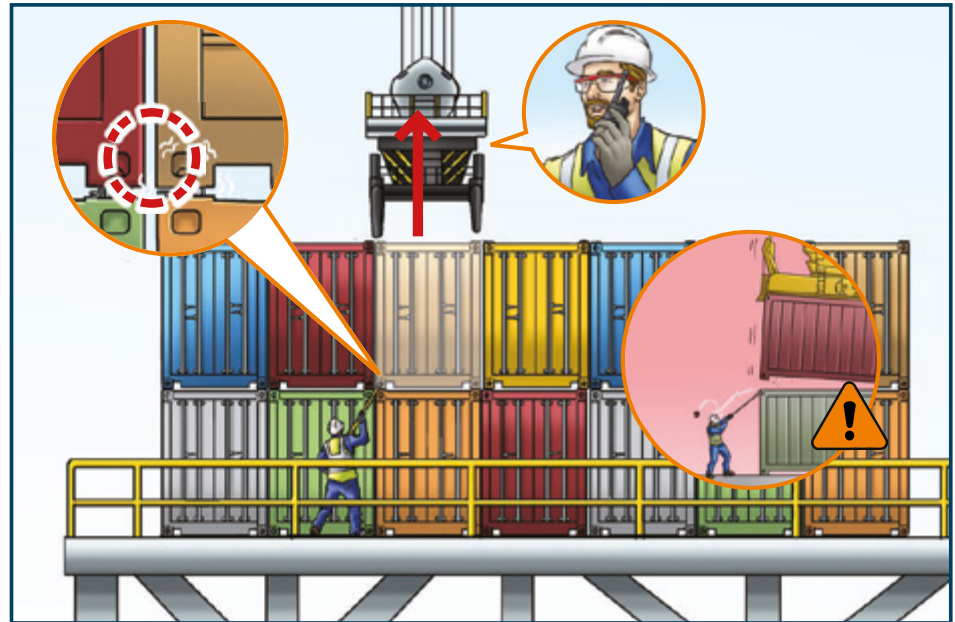

General good practices when unlocking stuck twistlocks:

If you try get a twistlock unstuck at a height of more than one container while it is lifted by the crane, and the twistlock falls out and hits you, you can be fatally injured.

Note: please refer to Working at Height Visual Work Instruction.

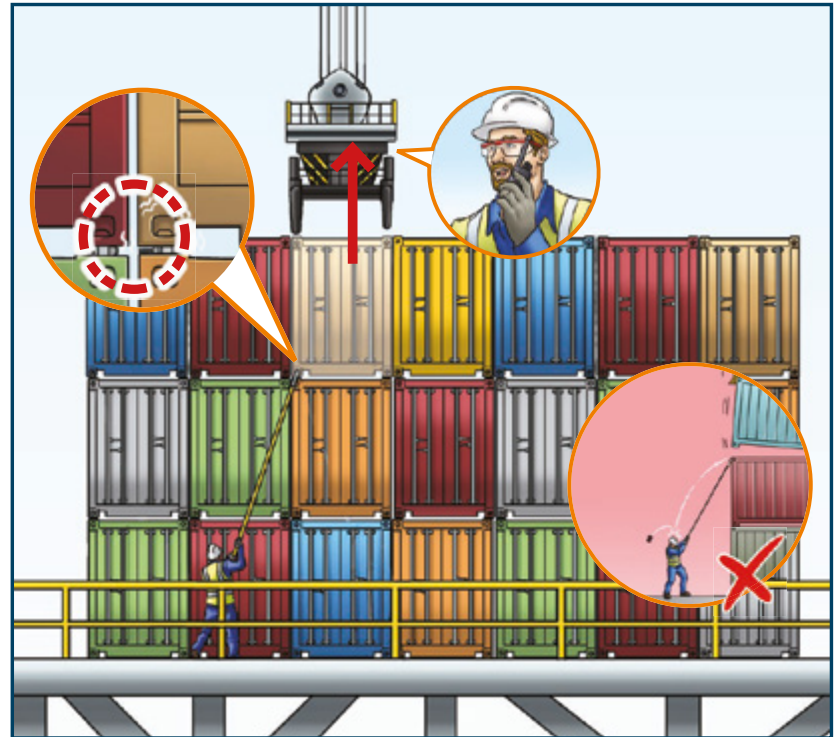

General good practices when unlocking stuck twistlocks:

In situations where the usual troubleshooting methods have not worked to free the container, you will need to take other steps. You may try other safe and risk-assessment methods to free the twistlock, or the PIC can report the issue back to vessel command to resolve.



14. Working at Height during Lashing and Unlashing

Dangers:



Falls from height or falling overboard.



Crush injuries.



Pendulum effect injuries. Falling overboard. Suspension trauma.

Releasing twistlocks at height

Once the lashing cage or Gondola is attached to the spreader, ensure secondary attachments are secured before anyone is lifted.

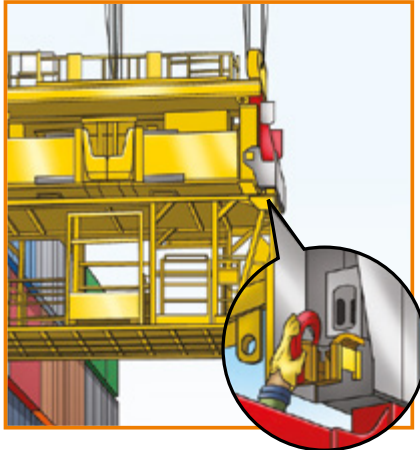

In addition to standard PPE (refer to PPE VWI), you must wear a harness secured by a lanyard to a fixed, centre-mounted static line or other recognised anchorage point (refer to anchor points Visual Standard).



Releasing twistlocks at height

Use a safety harness with a double lifeline inside the cage. Keep your arms inside the cage while it's being lifted or moved and ensure lashing tools are secure.

One anchor point per lasher, UNLESS anchor is rated for 2 people and tested to withstand more than 22kN of force.

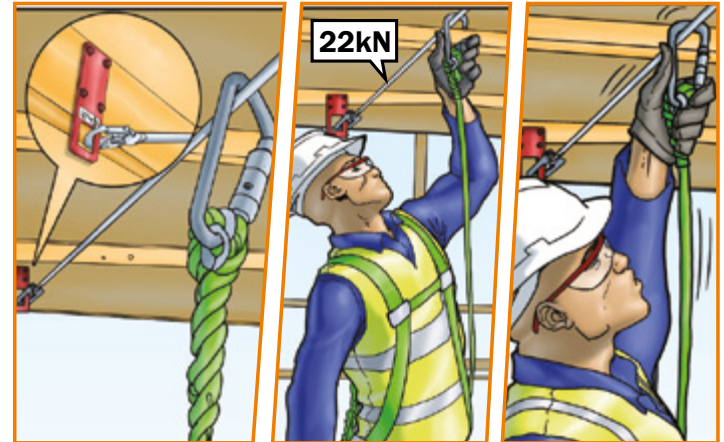
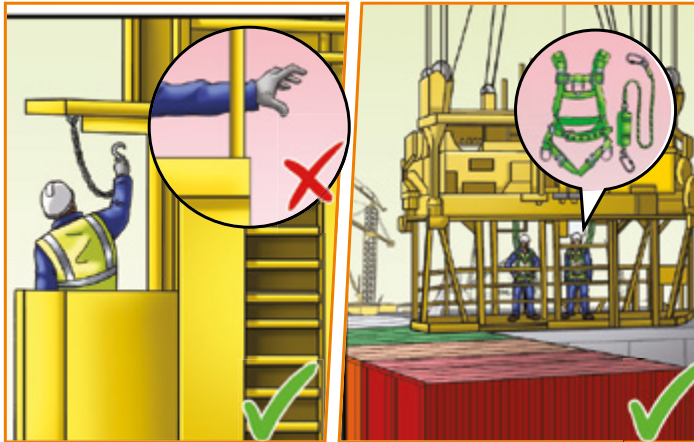

Releasing twistlocks at height

Don't work in the same bay below a Gondola/SWC when they're in use. Attach extendable lashing poles to the Gondola/SWC to prevent it from being dropped.

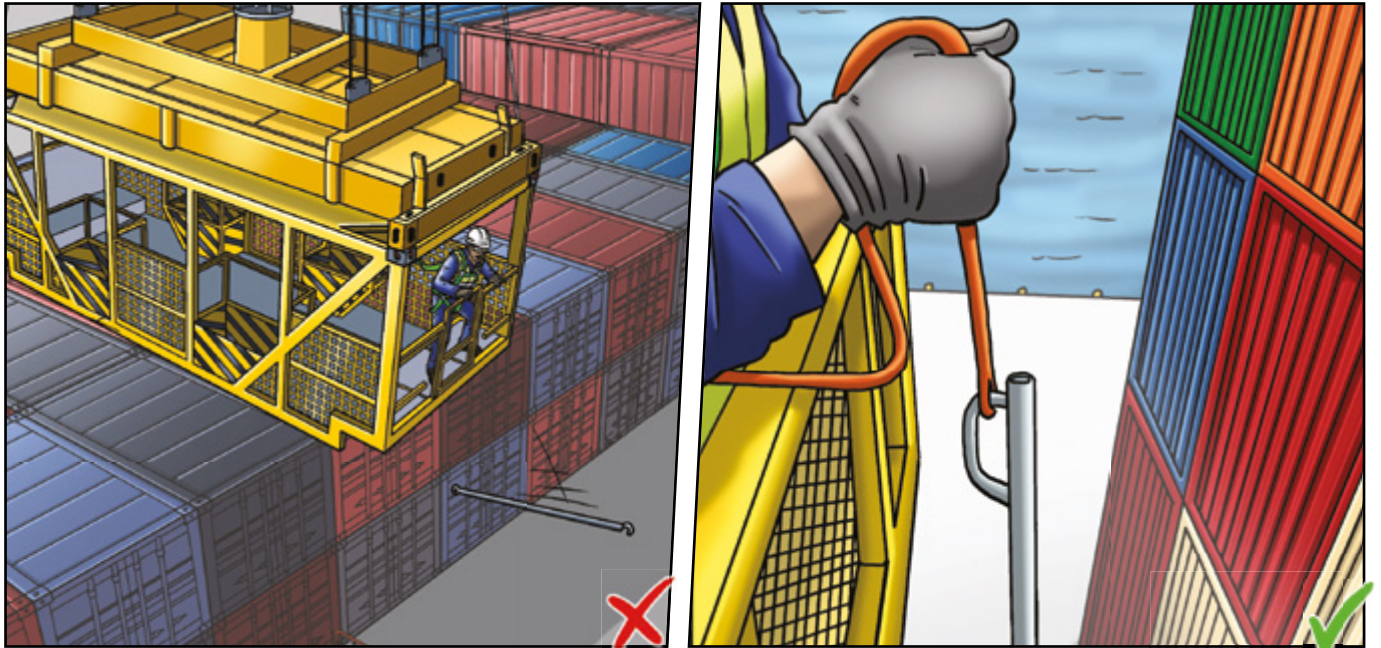

Releasing twistlocks at height

- A Person in Charge (PiC) must be in place for all working at height during lashing/unlashing. The PiC must also ensure the area where the work at height is taking place is cleared of people.
- The Person in Charge (PiC) must maintain radio contact with the crane operator to direct the operations.
- In a lashing cage, one person must have a radio and be designated the Person in charge (PiC). In a gondola there should be a designated Person in charge (PiC) with radio as well.

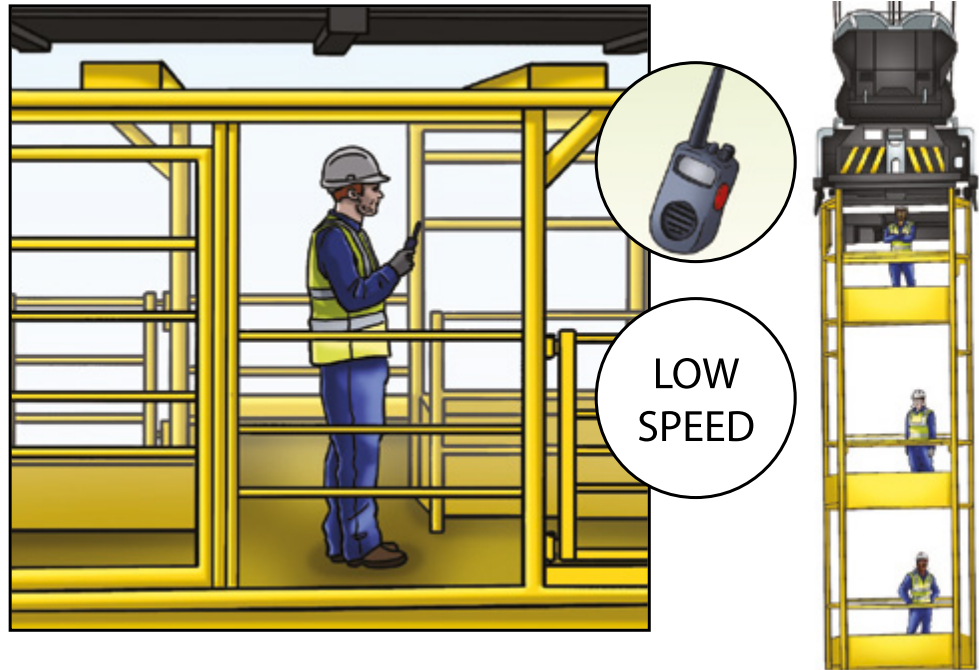

Releasing twistlocks at height

Exception handling: container-top work on vessel

It is the responsibility of the vessel master for twistlocks and other lashing equipment to be in working order. Work outside of a lashing cage at height is a high-risk activity and should only be done in exceptional circumstances. Refer to the Stuck Twistlock Troubleshooting VWI, the Fatal 5 Working at Height VWI and the Working at Height toolkit for this type of work.

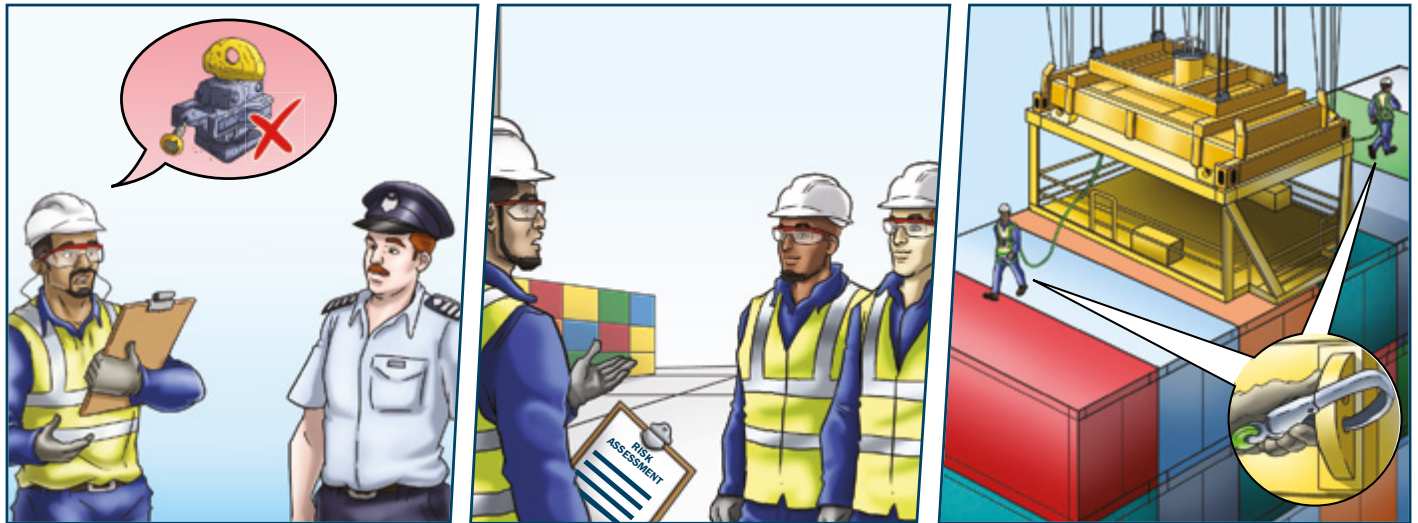

Releasing twistlocks at height

Working at height on a vessel:

Lashing or unlashing activities should not occur next to an open hatch. The loading/discharge and lashing plans should eliminate the need for this.

If lashing MUST occur adjacent to an open hatch, it should only take place if a rigid and permanent guard rail is in place. Temporary guardrails and the use of fall restraint/arrest equipment are less effective barriers. Lashing next to an open hatch needs to be risk assessed and mitigated before start.

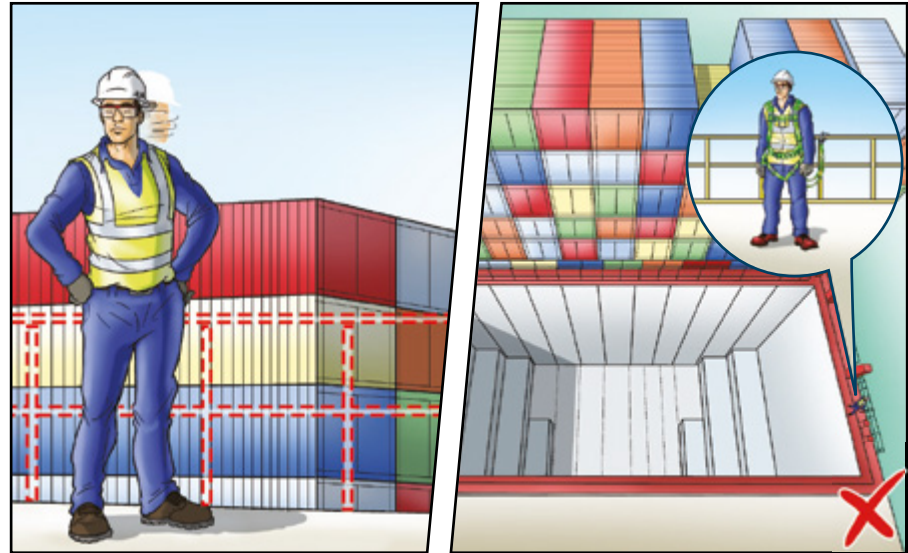

15. Lashing and Unlashing Working in Pairs

Dangers:

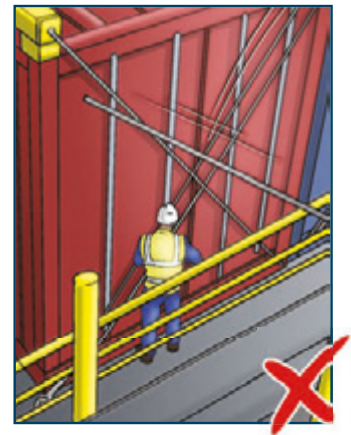
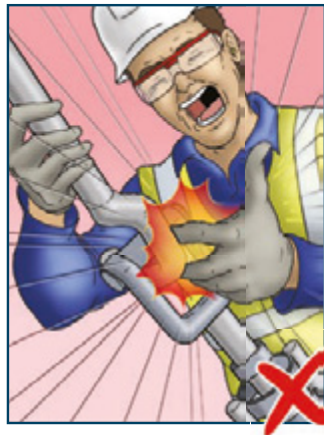

Working in pairs

Performing lashing operations alone can put physical strain on your body, which can result in injuries, and make doing the actual work more difficult.



Working In Pairs

Supervisor & Foremen must split tasks in pairs so that two people can work together. Releasing or locking twistlocks – you must work on the same level of the same walkway and be within eye-sight of each other.



Working In Pairs

Lashing or unlashing – you must work together to place, connect and tighten the lashing bar to the turnbuckle.



Working in pair:

There's no need to pre-hang lashing bars, which could fall and hit someone.

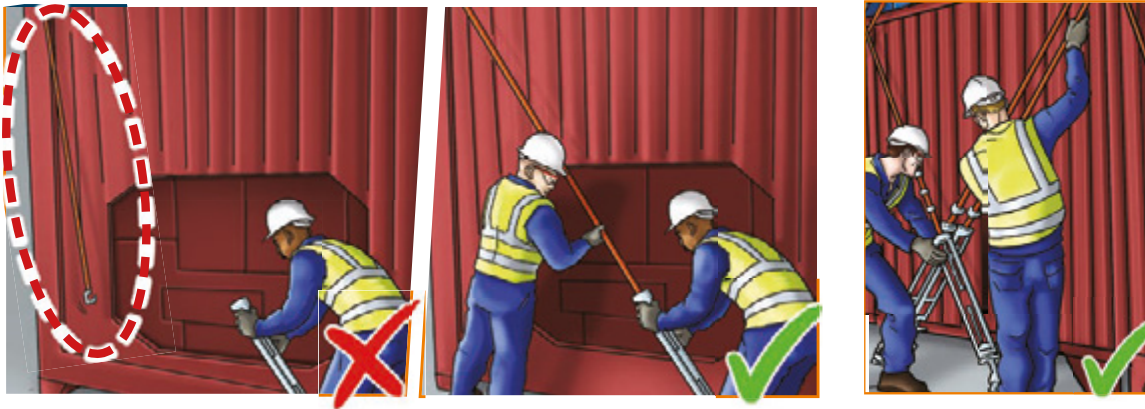

Only one lasher can use the lashing bar while the other tightens up the turnbuckle with a spanner. This also allows you to use both hands so there's less chance of slipping or getting your fingers caught.

Working in pair:

You can perform proper manual handling to reduce the chances of injury and physical strain on your body.

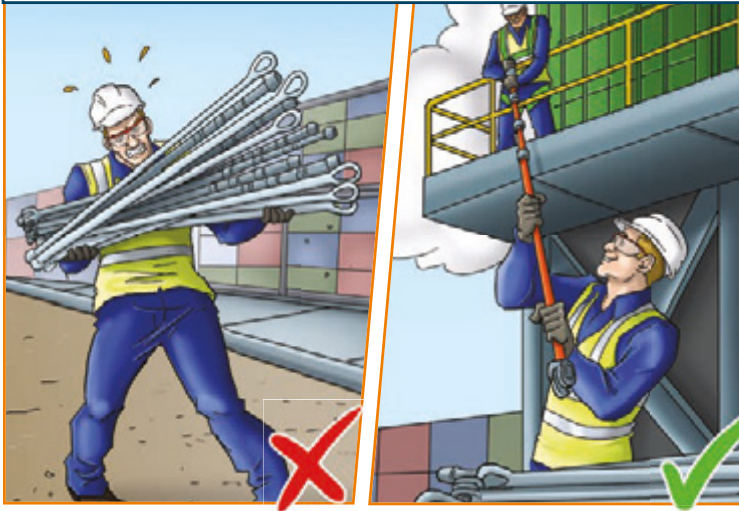

Your colleague can keep an eye on you and raise the alarm if needed. For example, if you slip while working on a wet surface.



Working in pair:

Supervisors and foreman must be present on the work site and supervise and check if work is being done in pairs.



16. Out of Gauge (OOG) using STS Cranes

Poorly planned stows, a lack of adequate lifting equipment available and OOG cargo being moved by shiptoshore (STS) cranes have been a significant factor in serious injuries and damage.

Dangers:

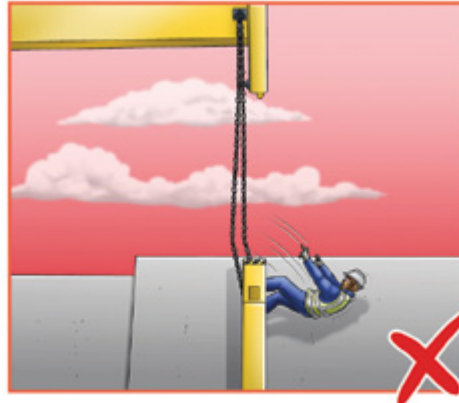
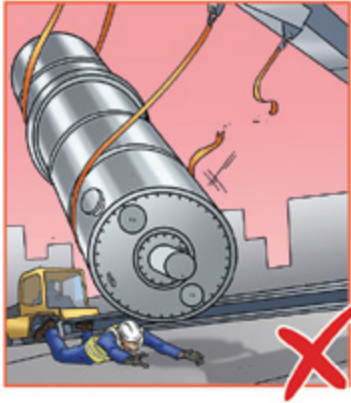

Poorly planned stows, a lack of adequate lifting equipment available and OOG cargo being moved by DSTS cranes have been a significant factor in serious injuries and damages.

Out of Gauge (OOG) Handling

Receive shippers' instructions and BAPLIE files, including lift plans and schematics of specific cargo, as soon as possible from the port of load to enable the correct sourcing of lifting equipment and for planning.

Establish traffic management controls, including cargo lay down areas, pedestrian safe zones and load/discharge areas. Ensure all prime movers are stopped from entering the lift zone until the lift has been successfully completed.

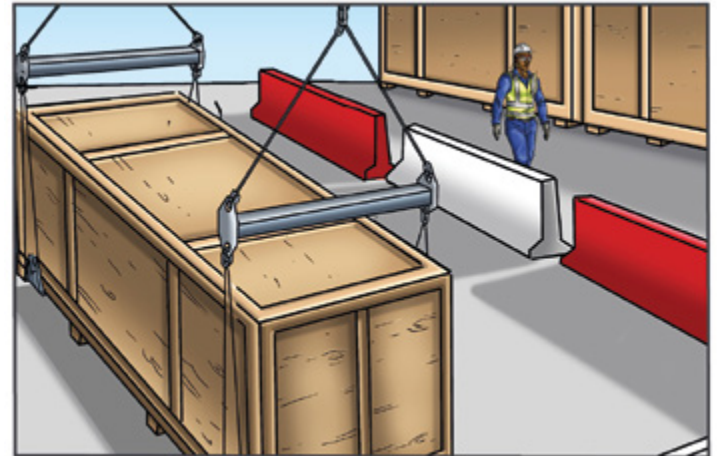
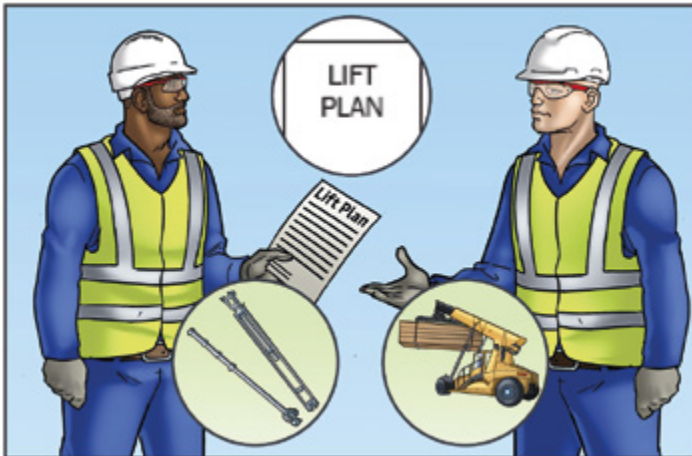

Out of Gauge (OOG) Handling

Determine the lifting methodology using the spreader or heavy lift hook and spreader beam.

Wherever possible, use automatic over height spreaders to minimize working at height exposures. Where required to work at heights, utilize a work cage and establish working at height controls to protect workers.

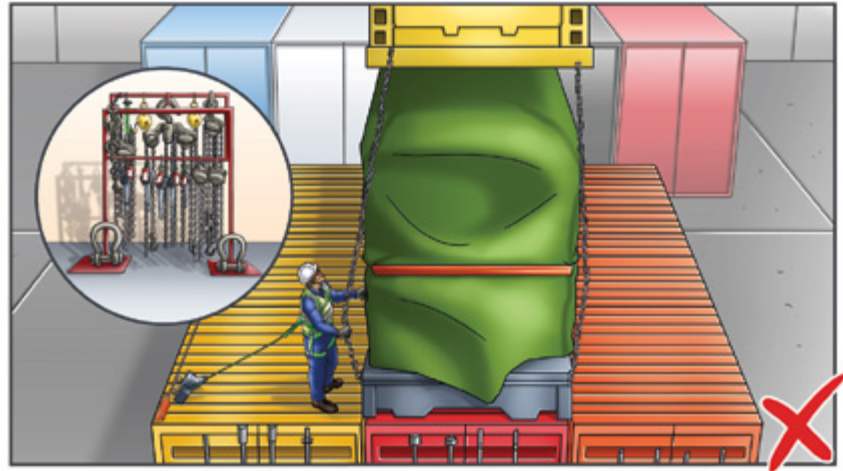
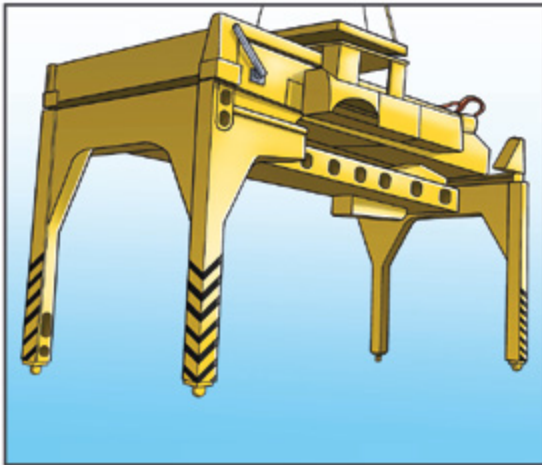

Out of Gauge (OOG) Handling

Establish a safe means of accessing cargo, including landside and vessel operations.



Manage environmental conditions such as lighting, wind, air quality and heat. Only enter holds once the hatch has been removed and ventilated.

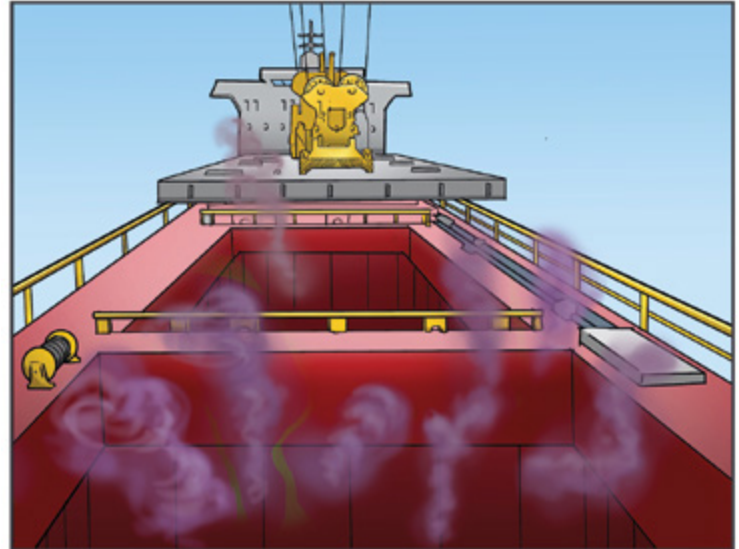

Out of Gauge (OOG) Handling

The Person in Charge (PIC) or other competent persons must first assess the cargo to find out the working load limit (WLL), damage, size and composition.



The PIC must ensure all personnel are clear of loads before being lifted. Use lanyards or lead lines to move cargo, where possible. When in doubt do not lift.

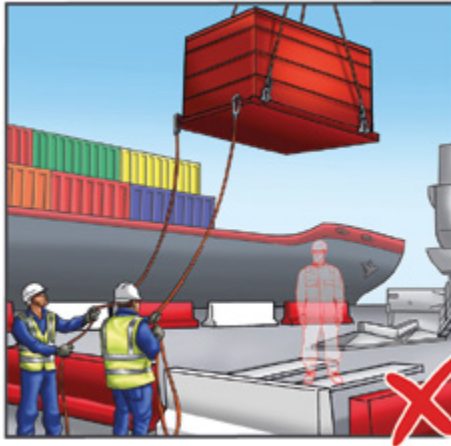

All personnel must ensure they understand safe zones and working at height risks. Never stand under a suspended load, maintain container separation.

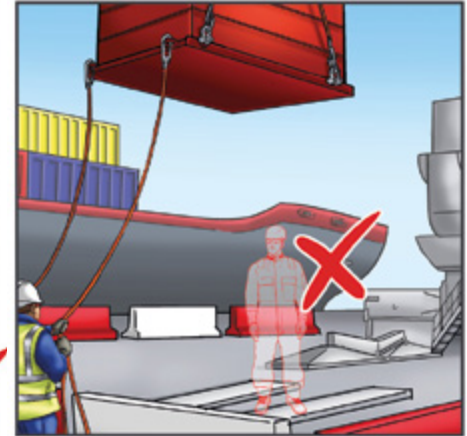

Out of Gauge (OOG) Handling

Where OOG need to be loaded onto a trailer, lower the OOG to above trailer height and reverse the trailer underneath it.

Maintain radio communication with the crane operator at all times. Stop if communication breaks until it's established again.



Out of Gauge (OOG) Handling

The PIC must be competent in the selection of the equipment and methodology for lifts. All other personnel involved must be trained and competent in the loading/discharge of general cargo and slinging techniques.



Out of Gauge (OOG) Handling

Maintain all load-handling equipment (including spreaderbeams, wires, slings, chains and attachments) according to the Original Equipment Manufacturer(OEM). A competent person must also inspect them before use and according to site requirements.

The operator must perform a pre-operational inspection of vessel gear. All vessel gear must have in date certificates. If it's missing or out of date, do not use.

A safety cage must be available for all vessel operations in case of an emergency to manage working at heights activities.

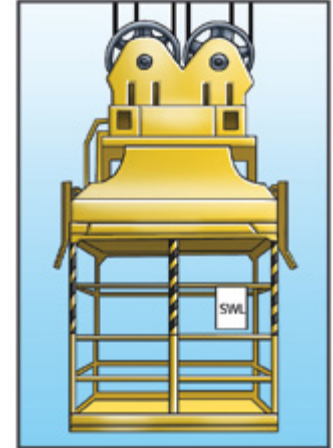
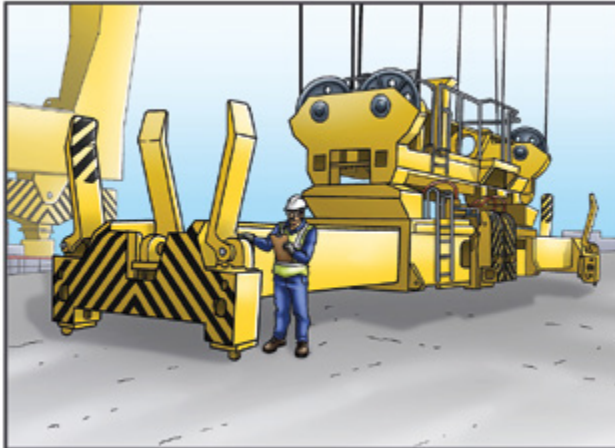

17. Packing and Stripping Containers (x-staffing)

Dangers:

Manually packing and stripping containers has led to a number of workers being significantly injured or killed, so it's important to manage these operations properly.



Struck by moving cargo.



Struck by forklifts.



Overcome by a lack of oxygen/fumes.

Safe Cross-staffing

Establish laydown areas for packing and stripping containers to restrict container movements and prohibit any pedestrian movements. Use container corner blanks to prevent unintentional movement.



Safe Cross-staffing

Based on the work plans, establish traffic management flows for the safe movement of pedestrians and small forklifts in the laydown areas.



Safe Cross-staffing

The Person in Charge (PiC) must allocate labour and equipment in line with the work plans, including the priority of work, to ensure containers are packed, stripped or transported safely.

All containers that carry dangerous cargoes or are identified as fumigated (Methyl Bromide), must be communicated to work teams with specific controls adopted in line with the safety data sheets.



Safe Cross-staffing

Atmospheres inside containers may be unsafe. No person should enter a container until it has been confirmed as safe. Each container identified for stripping must be ventilated before entry. E.g at least 30 minutes using mechanical ventilation or 12 hours with natural ventilation.

Use a short rope and watch for falling cargo when opening the container doors.



Safe Cross-staffing

Where there is any doubt about the safe atmosphere of a container, stop work and get clarification from the PIC. Each site must have equipment available for testing atmospheres.



Safe Cross-staffing

Wherever possible, use mechanical means, such as forklifts and roller bed conveyors, for packing and stripping at ground level.

Secure forklift ramps to containers at all times and don't use diesel or petrol-type forklifts to handle chemicals. All packing must be in accordance with the CTU code.



Safe Cross-staffing

Only move palletised cargoes or pallets used for moving cargo when workers are clear. E.g. forklifts only pick up pallets inside containers when instructed to do so.



Safe Cross-staffing

No workers are allowed inside the container when cargo is being moved with a forklift.



Safe Cross-staffing

Consider the weight and size of goods when physically handling cargo. Where possible, work in pairs and rotate jobs to reduce manual handling risks.



Safe Cross-staffing

Consider poor lighting and adverse environmental conditions, such as heat and poor ventilation.



18. Rental Equipment Management

Hierarchy of controls

The hierarchy of controls is used to manage risk. Each step involves controls that go from most effective (Elimination) to least effective (PPE). We can apply the hierarchy of controls when renting equipment to ensure we're using the safest method possible.

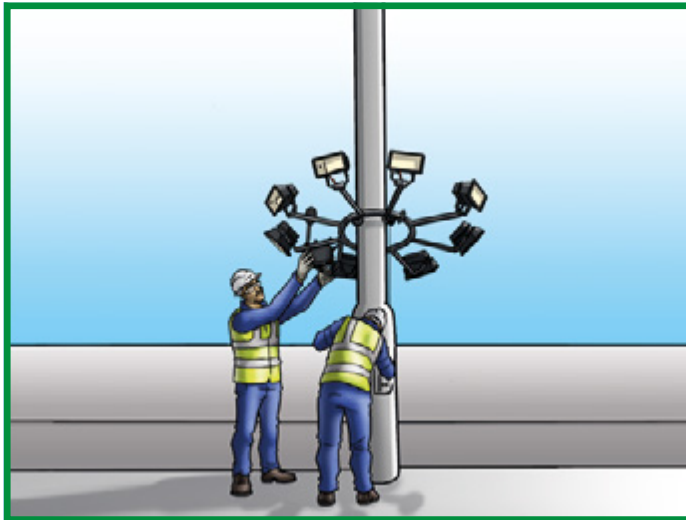

1. Elimination

The best way to reduce a risk is to eliminate it. For example, instead of using a Mobile Elevated Working Platform (MEWP) to clean and maintain light fittings, install lighting masts with winch systems to lower light fittings to the ground.

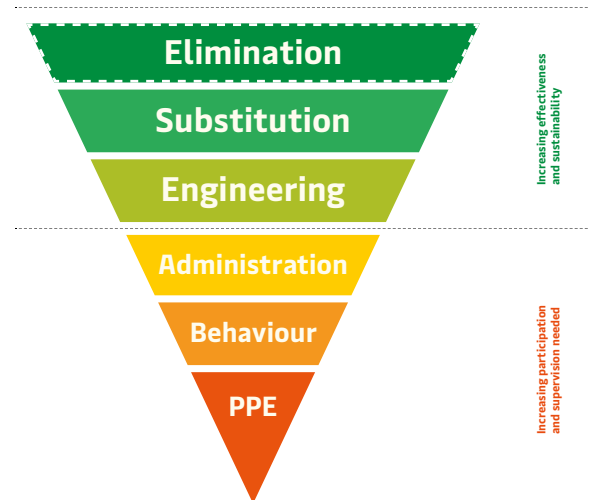

Hierarchy of controls



2. Substitution

The best way to reduce a risk is to eliminate it. For example, instead of using a Mobile Elevated Working Platform (MEWP) to clean and maintain light fittings, install lighting masts with winch systems to lower light fittings to the ground.

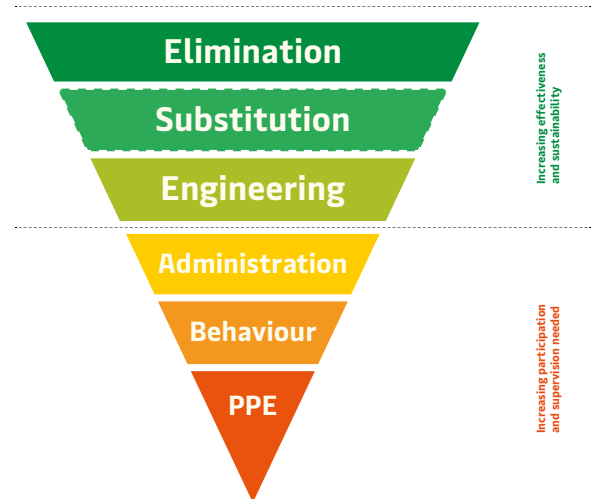

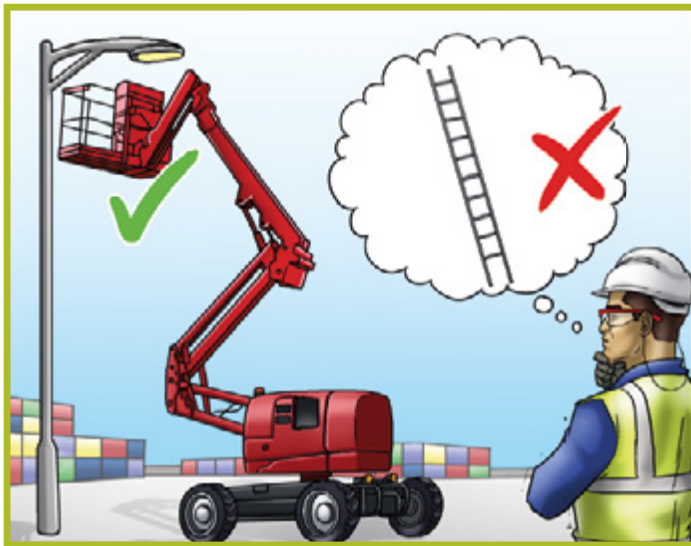

3. Engineering controls

Where it is still necessary to use a MEWP for light cleaning and maintenance, review the regulations and guidelines for the most suitable equipment for the task.

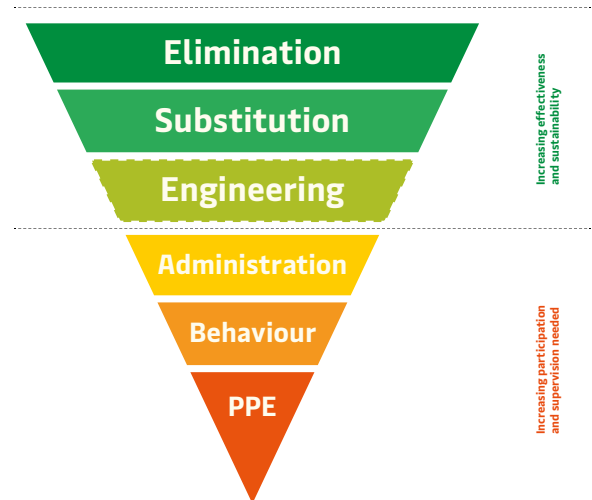

Hierarchy of controls

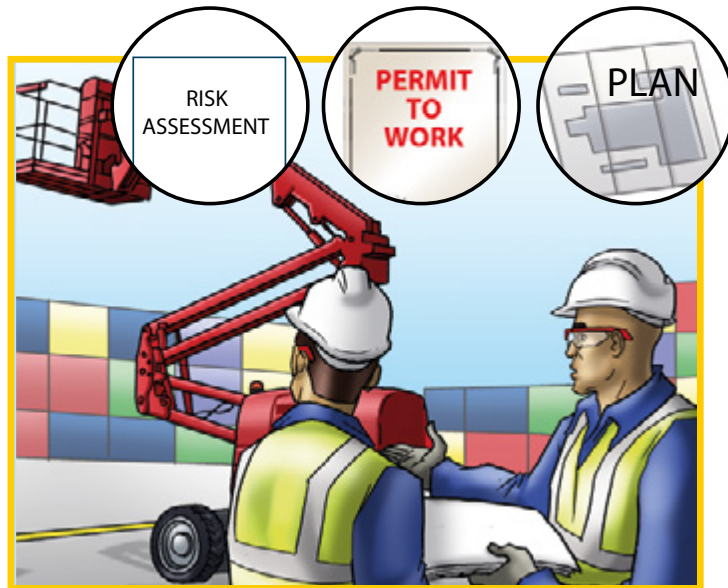

4. Administration

The terminal ensures all required certification is in place for both equipment and operators, where supplied. Ensure task risk assessments, permit to work, detailed work plan, etc. are all in place.

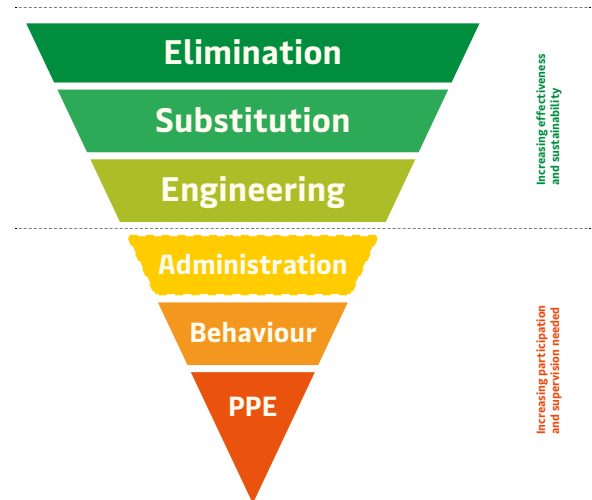

Hierarchy of controls



5. Behaviour

The terminal ensures all personnel (staff and third party/ contractors) involved in the task have the necessary training to perform the task and operate the equipment.

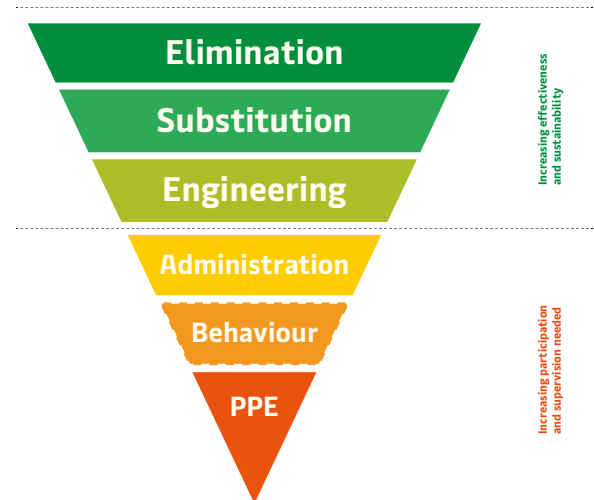

Hierarchy of controls

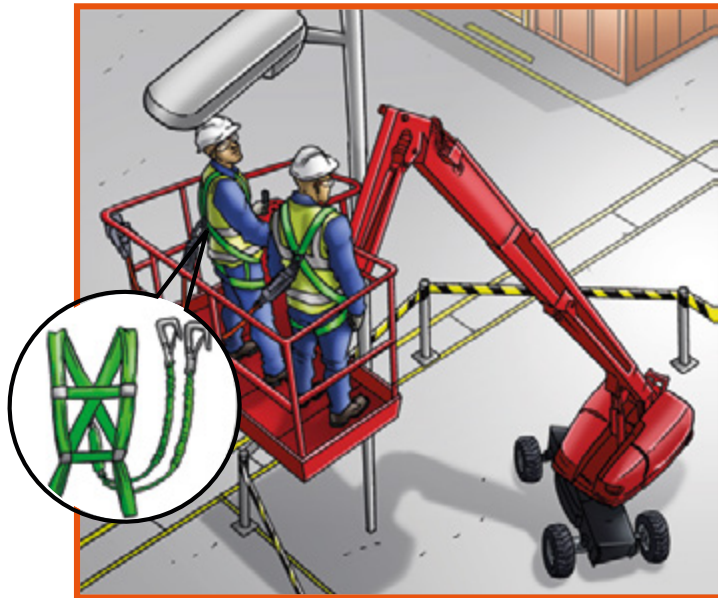

6. PPE

The terminal ensures all operators, and those supporting them, have the correct PPE. They must also ensure operators are trained on how to use the PPE and that the PPE has been tested, certified and is fit for purpose.

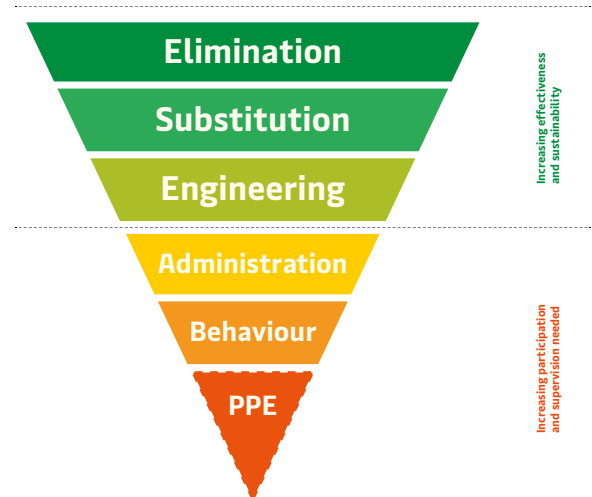

Rental Equipment Management

APM Terminals is introducing a new rental equipment management process to help ensure that when we do rent equipment it meets APMT and local Health, Safety and Environment Standards.

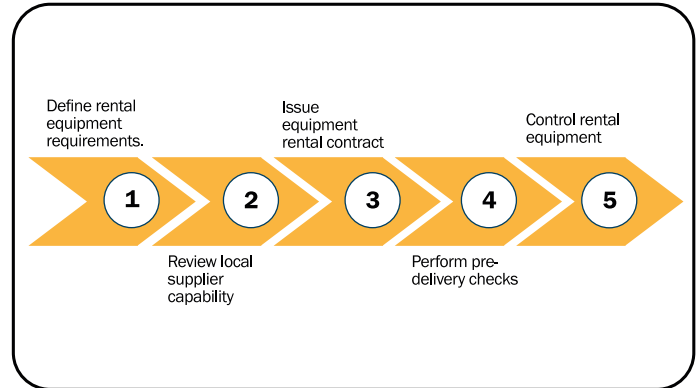
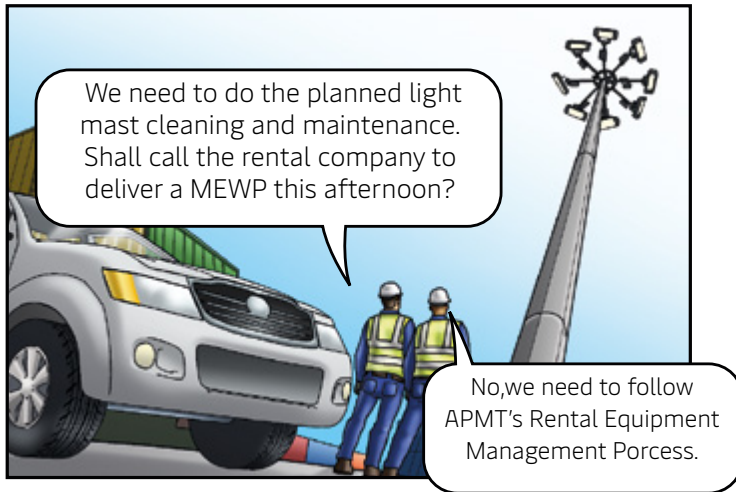

Rental Equipment Management

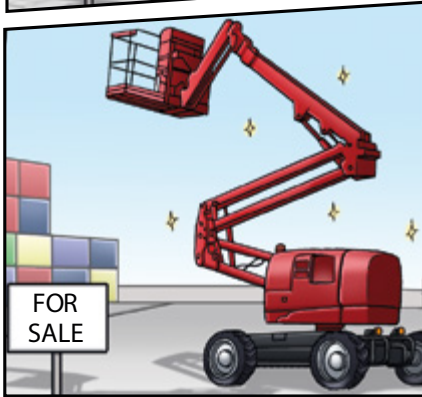
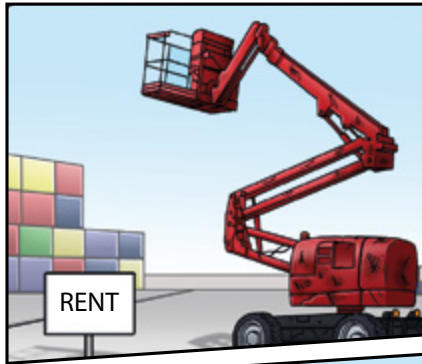

But how will we know if it's safe to use?

They must provide all their records.

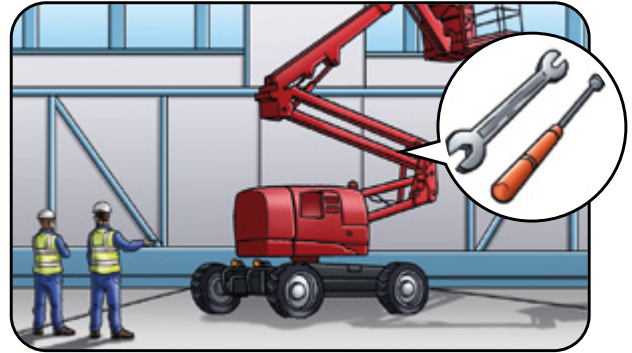

Rental Equipment Management



Rental Equipment Management

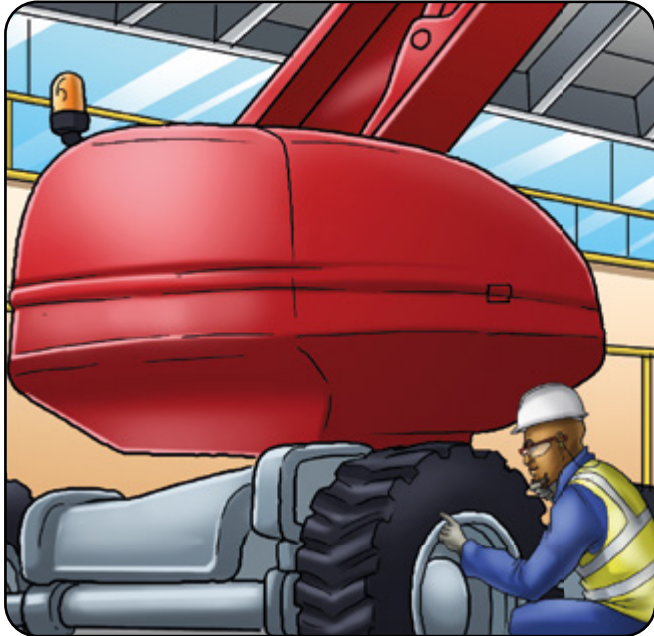

Rental Equipment Management

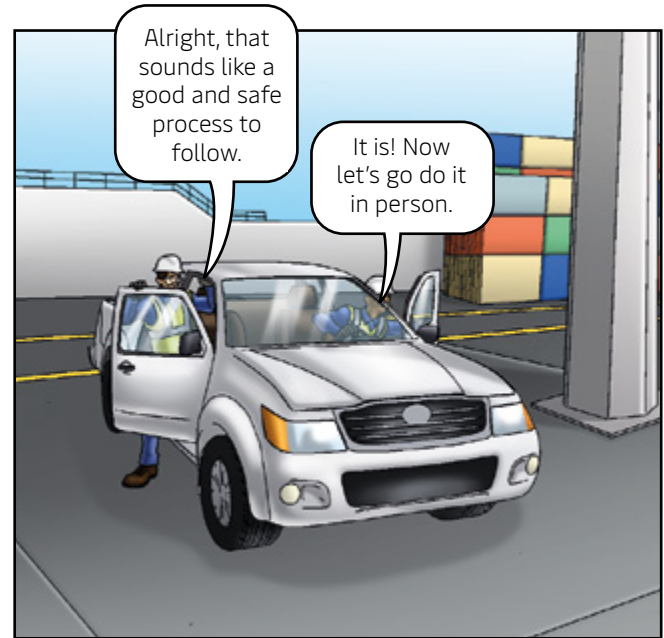
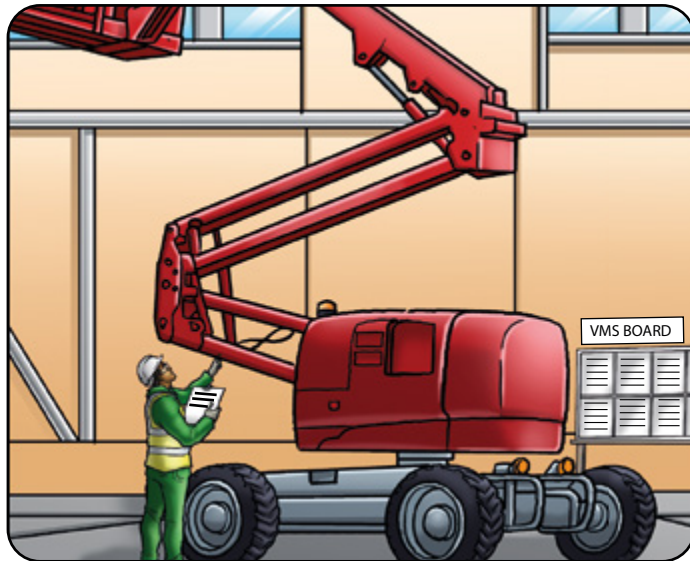

19. Tyre Management

Dangers:

Servicing tyres or rims can be dangerous: either while performing the service or if tyres have been serviced incorrectly.



General

Only service tyres if you are trained and competent.

Always follow the tyre/ wheel manufacturer's instructions and procedures.



General

Ensure you have the correct tools available and inspect them before use.

Don't use metal or steel hammers; only use rubber, plastic or brass mallets.



Inspections

Follow tyre industry recommended inspection procedures. Never try to re-inflate a tire on equipment which is less than 80%.



Inspections

Look for physical damage to the rim, the wall of the tyre, cracks or under- or over-inflation. Never stand facing the wheel being inspected.

Remove rust, dirt, or foreign material from tyres, rims and wheel- mounting surfaces.



Inspections

Look for physical damage to the rim, the wall of the tyre, cracks or under- or over-inflation. Never stand facing the wheel being inspected.

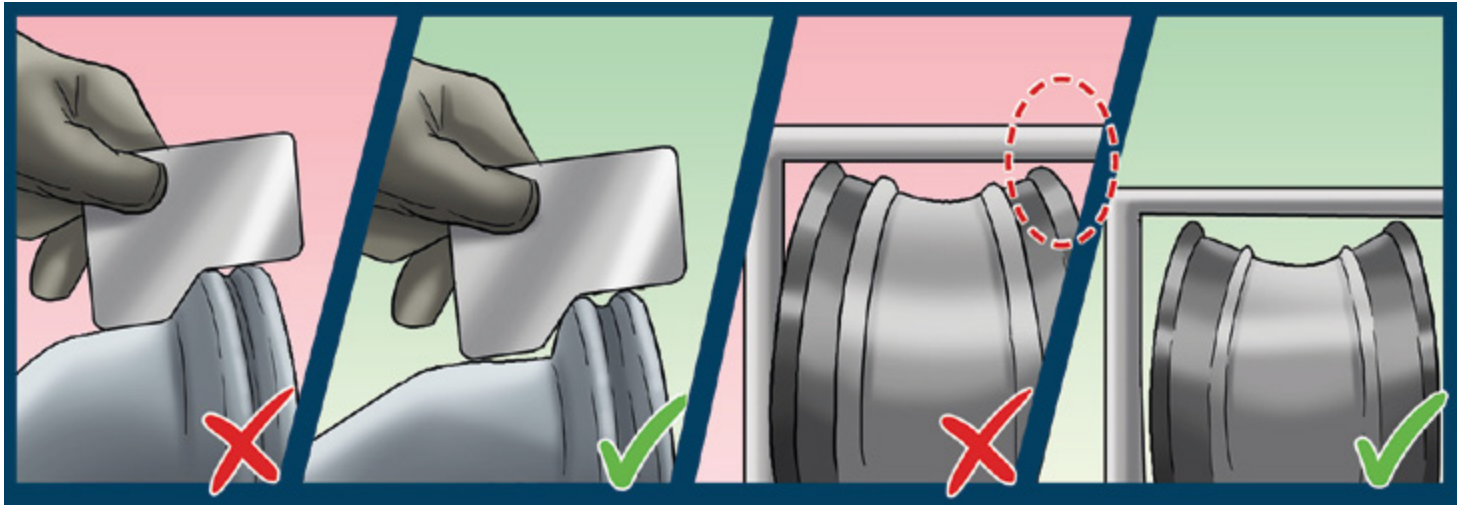

Inspections

Never rework, weld, heat or braze any rim parts or components.



Clearly mark and remove all unserviceable parts from the service area.



Servicing single and multi-piece rims

Always use an engineering approved tyre cage for all tyre inflations. Stop inflating if bulging occurs or you hear snapping, cracking or popping noises or zipper distortions are present.

Inflate to 10 psi, stop to inspect the tyre while it's still inside the cage and, if everything is in order, continue inflating in increments of 10 psi to the recommended pressure for single-rim wheels.

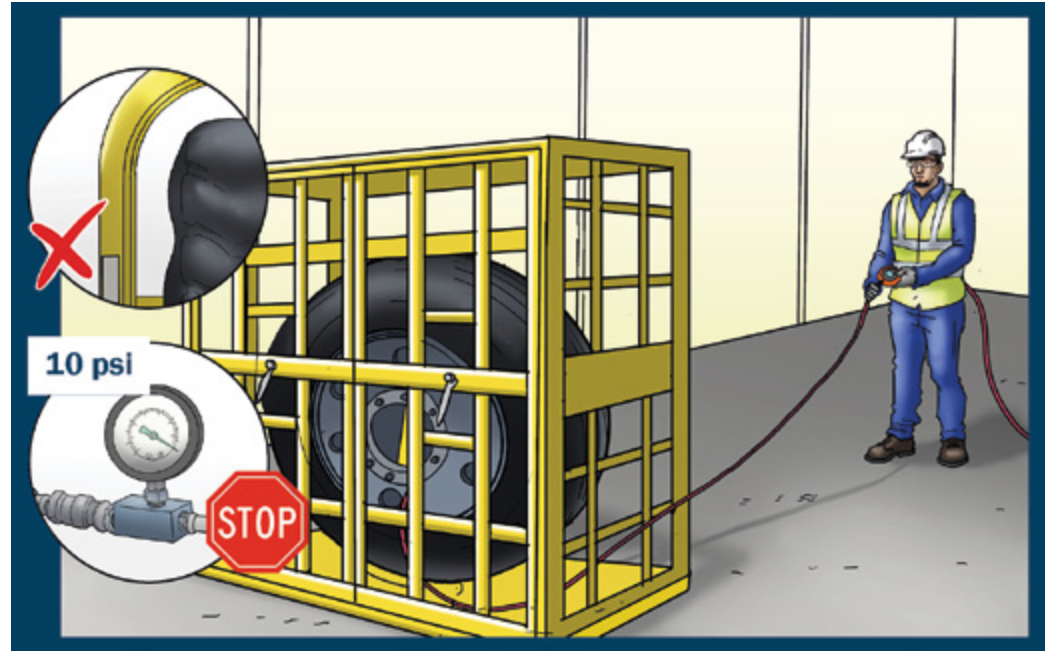

Servicing single and multi-piece rims

Only inflate multi-rim wheels past 10 psi when inside a mobile cage / restraining device. Inflate the tyre in increments of 10 psi, checking to see if the rim has seated. DO NOT inflate the tyre past 40 psi if the rim is seated - the tyre needs to be immediately deflated and inspected. (Once the rim is seated, continue to inflate in 10 psi increments to recommended cold pressure in the cage and deflate the tyre back to 10 psi for transport).



Servicing single and multi-piece rims

Only inflate a multi-rim wheel past 10 psi when the wheel is mounted and fully secured on the machine, in line with the manufacturer's recommendations. A retraining device must be used to protect people prior to any inflation.

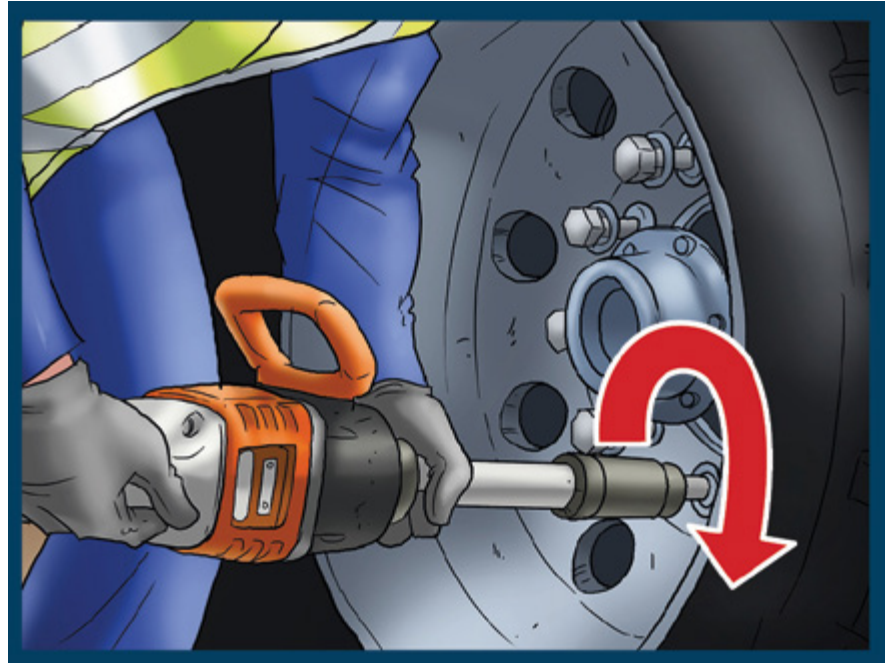

Servicing single and multi-piece rims

Always use mechanical means to move tyres and rims.



Servicing single and multi-piece rims

Never stand in front of the tyre or valve when it is being inflated or deflated.

Always ensure a clip-on clutch, quick release and in-line pressure gauge is used with at least 2 meters of hose.

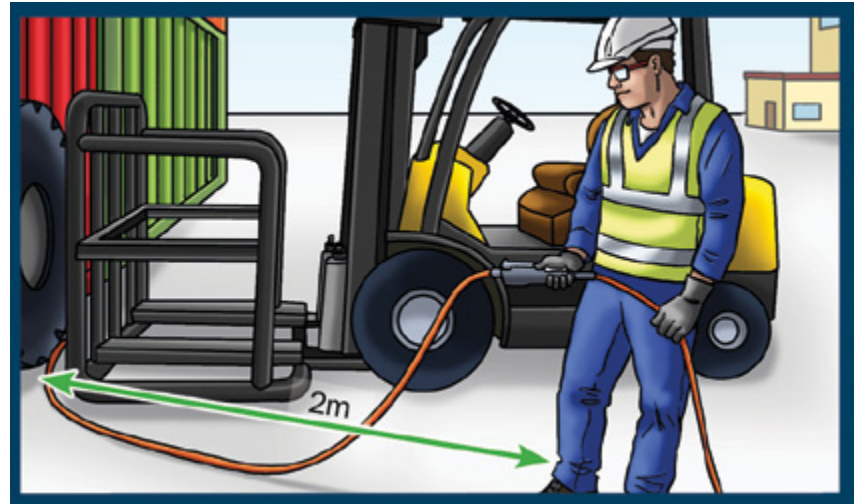

Servicing single and multi-piece rims

Use a system to store multi-rim tyres. Do not exceed 10 psi when in storage. All tyres under pressure must be stored away from pedestrians.

Ensure tyres are secured and transported safely. Never stand in the trajectory or use a tyre that has been dropped in transport.

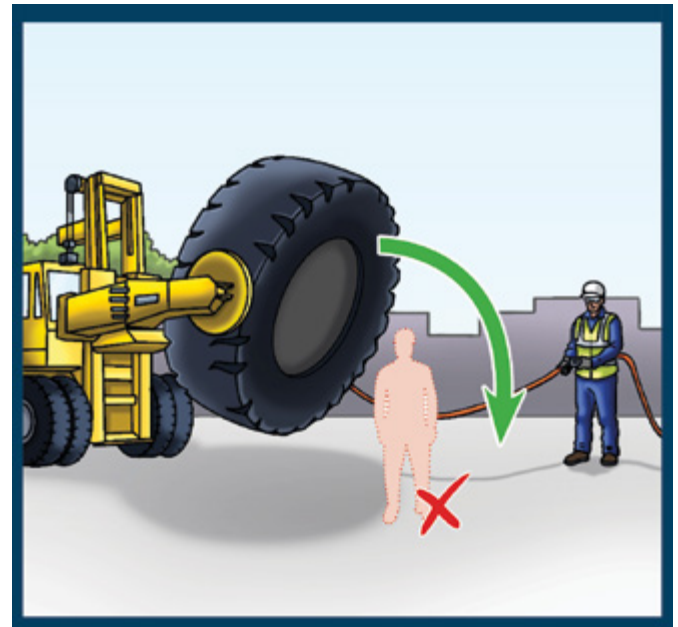
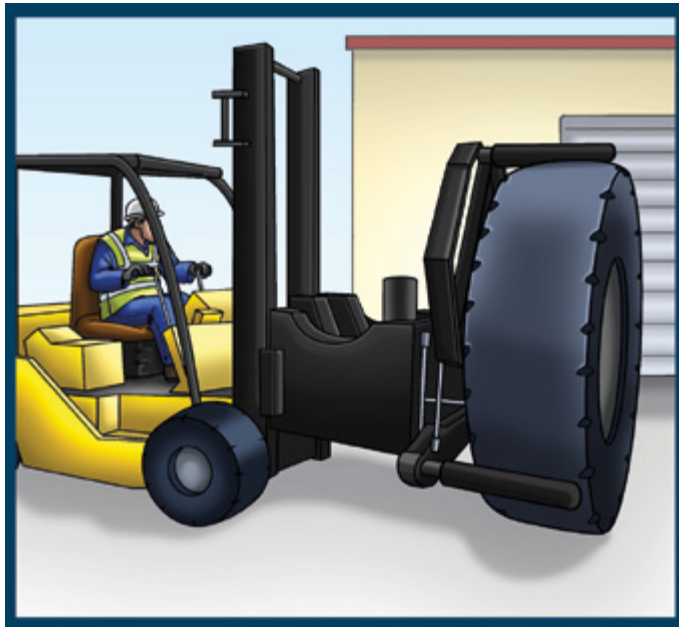

Critical Controls:

Deflating:

Totally deflate the tyre and remove the valve prior to removing any wheel nuts and taking the tyre off.

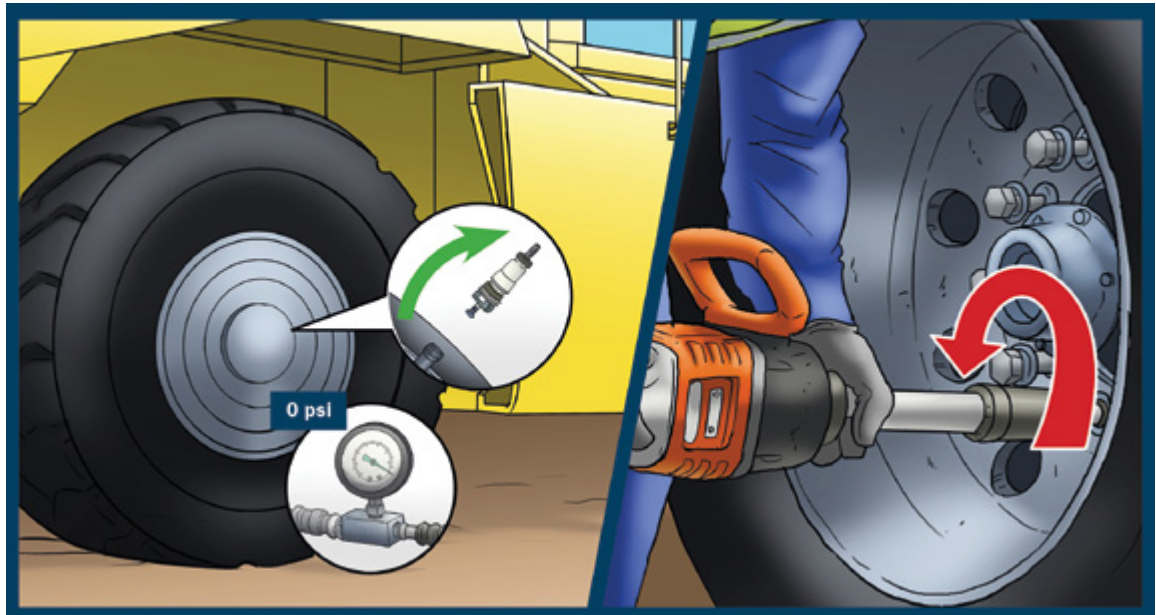

20. Working with High Voltage

Dangers

We have had a number of severe injuries and fatalities across our industry due to working with or near high voltage (HV > 1,000V) electrical equipment and, in particular, arcing.

Electrocution



Being blown back



Fires and explosions

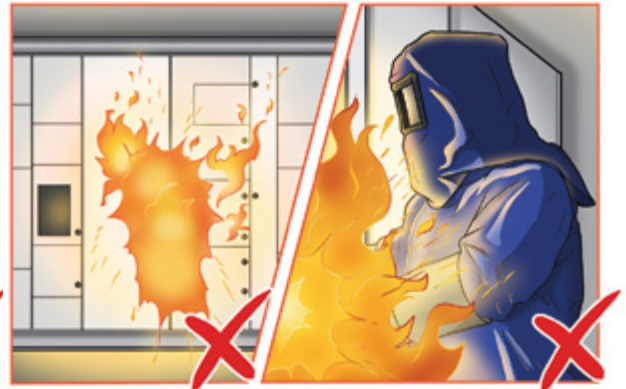

High Voltage

You may only work on or near HV installations if you have undergone the necessary regulatory/OEM training.

Make sure all HV installations, such as substations, are locked and/or have systems to prevent unauthorised access.

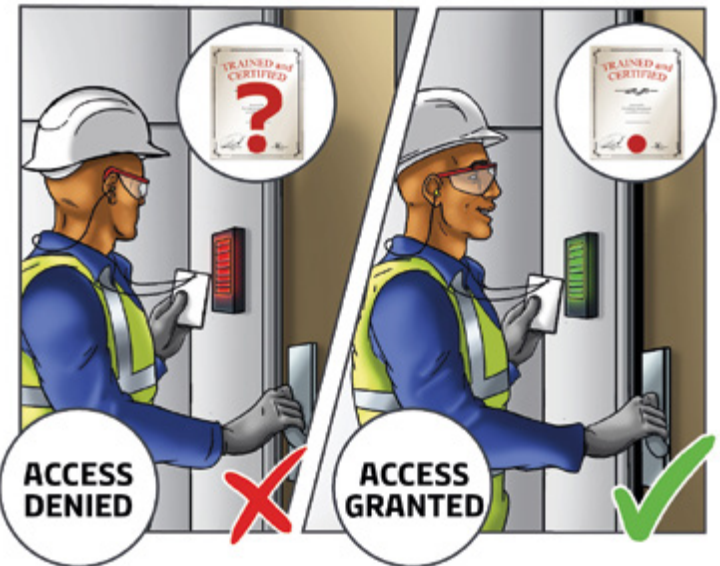

High Voltage

A risk-based work instruction for all electrical work is a must.

The most effective way to prevent arc-flashes is to de-energize equipment. Assume equipment is energized until proven to be de-energized.



High Voltage

When working with energised HV, determine the safe working distances. Safe work distances need to be calculated for each piece of equipment. Only HV-qualified personnel are permitted within zones 3 and 4.

Never work alone when working on HV installations. All non-electrical workers in zone 0 must be supervised by an authorised person. Safety zones must comply with NFPA guidelines.

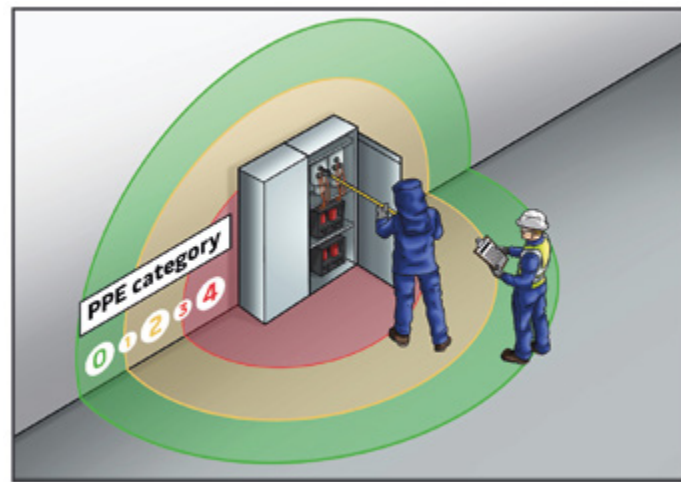
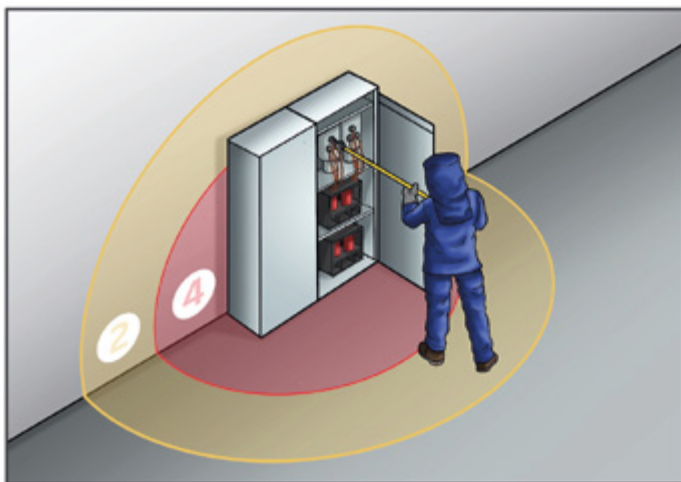

High Voltage

Carbon Dioxide (CO₂) fire extinguishers and, where identified, a fire suppression system must be in place.

Use electrical isolation points that are integrated into the site lockout/tag out (LOTO) system.

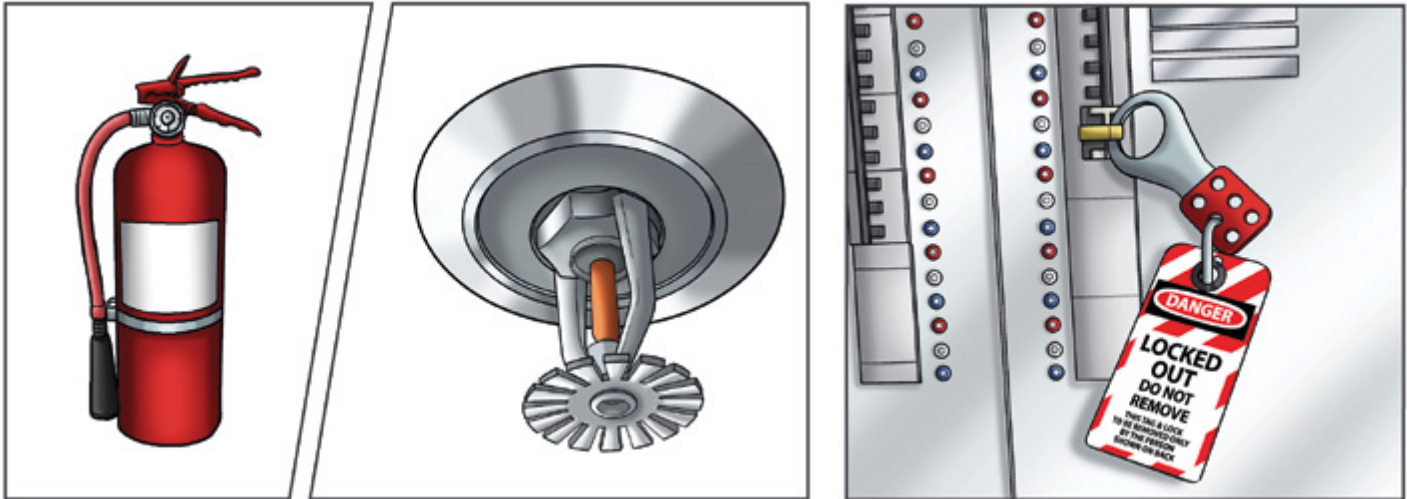

High Voltage

Rubber matting, rated to IEC61111 requirements, must be installed at all switchboards.

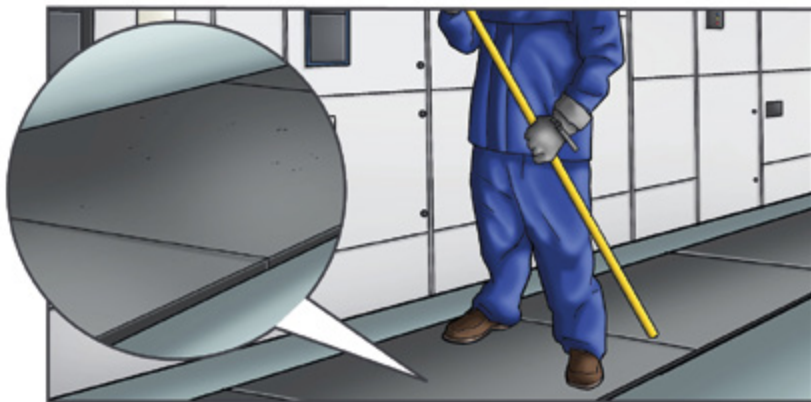





Ensure all substations or other HV areas are kept clean and free of debris.



High Voltage

Determine the arc flash boundaries to identify the required: PPE, and Level of training and awareness.

PPE CATEGORY 0	PPE CATEGORY 1	PPE CATEGORY 2	PPE CATEGORY 3	PPE CATEGORY 4
				
<p>No protection</p>	<ul style="list-style-type: none"> • Arc-related long sleeve shirt • Arc-related pants and overalls • Arc-related face shield with hard hat • Safety glasses • Hearing protection • Leather and voltage-related gloves (as needed) • Leather work shoes 	<ul style="list-style-type: none"> • Arc-related long sleeve shirt • Arc-related pants and overalls • Arc-related face shield and balaclava or arc flash suit with hard hat • Safety glasses • Hearing protection • Leather and voltage-related gloves (as needed) • Leather work shoes 	<ul style="list-style-type: none"> • Arc-related long sleeve jacket • Arc-related pants • Arc-related flash hood with hard hat • Safety glasses • Hearing protection • Leather and voltage-related gloves (as needed) • Leather work shoes 	<ul style="list-style-type: none"> • Arc-related long sleeve jacket • Arc-related pants • Arc-related flash hood with hard hat • Safety glasses • Hearing protection • Leather and voltage-related gloves (as needed) • Leather work shoes

High Voltage

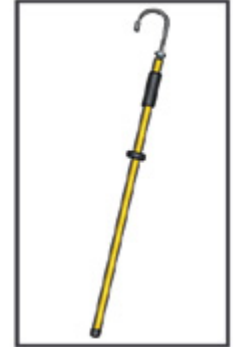

Inspect all PPE and replace it in line with the manufactures' requirements, when needed. As a minimum, always comply with EN/ANSI standards.



APM TERMINALS

Lifting Global Trade